



*Citation for published version:*

Newlands, MD, Paine, KA, Vemuri, NA & Dhir, RK 2008, 'A linear test method for determining early-age shrinkage of concrete', *Magazine of Concrete Research*, vol. 60, no. 10, pp. 747-757.  
<https://doi.org/10.1680/mac.2008.00004>

*DOI:*

[10.1680/mac.2008.00004](https://doi.org/10.1680/mac.2008.00004)

*Publication date:*

2008

*Document Version*

Publisher's PDF, also known as Version of record

[Link to publication](#)

Permission is granted by ICE Publishing to print one copy for personal use. Any other use of these PDF files is subject to reprint fees.

## University of Bath

**General rights**

Copyright and moral rights for the publications made accessible in the public portal are retained by the authors and/or other copyright owners and it is a condition of accessing publications that users recognise and abide by the legal requirements associated with these rights.

**Take down policy**

If you believe that this document breaches copyright please contact us providing details, and we will remove access to the work immediately and investigate your claim.

# A linear test method for determining early-age shrinkage of concrete

M. D. Newlands\*, K. A. Paine†, N. A. Vemuri\* and R. K. Dhir\*

University of Dundee; BRE Centre for Innovative Construction Materials

---

*For certain applications, the early-age dimensional stability of concrete can significantly affect aesthetics and long-term durability performance. The combined effects of plastic settlement, plastic shrinkage and autogenous shrinkage in fresh and hardening concrete will depend on mix proportions, constituent materials and environmental conditions as well as levels of crack inducing restraint. A new linear test method has been developed for measuring early-age shrinkage in concrete to allow investigation of the effects of new constituents on early volume stability. Single operator repeatability under laboratory conditions was investigated and the sensitivity of the test to varying temperature ( $20^{\circ}\text{C} \pm 2^{\circ}\text{C}$  and  $40^{\circ}\text{C} \pm 2^{\circ}\text{C}$ ), relative humidity ( $10\% \pm 2\%$ ,  $50\% \pm 5\%$ ,  $95\% \pm 5\%$ ) and wind velocity (7.5 km/h) was also determined. The test method was deemed suitable for use as a tool to measure the influence of new types of cements and aggregates on the early-age volume stability of concrete.*

## Introduction

Concrete often undergoes high levels of volume changes in its early age through a combination of moisture movement and thermal gradients owing to the hydration process or by loss of moisture to the substrate or evaporation to the atmosphere.<sup>1</sup> When restraint is present in the form of reinforcement or a substrate, cracking can occur and is particularly prevalent in early ages as concrete has little inherent tensile strength.<sup>2</sup> Early-age shrinkage is largely attributable to a combination of plastic shrinkage, plastic settlement and autogenous shrinkage and can cause significant cracking, compromising the durability and performance of concrete.<sup>3</sup> Free mix water moves towards the cast surface as the concrete is compacted and will evaporate in atmospheres of low relative humidity (RH). As the water moves through the concrete, capillary forces are formed inducing tensile stresses leading to shrinkage of concrete.<sup>4</sup> In addition, autogenous shrinkage, the bulk deformation of a closed isothermal cementitious material system<sup>5</sup> and chemical shrinkage, the volume

reduction associated with cement hydration<sup>6</sup> can also influence early-age shrinkage.

A number of studies have examined the early-age shrinkage cracking in concrete,<sup>7–15</sup> however, recent developments in concrete technology mean that a wider-range of cement and aggregate types are now being used, and understanding of the influence of these materials on early-age shrinkage is vital to enable competent concrete mix design and long-term performance; and to assist engineers in designing concrete mixes with minimal shrinkage. Consistent with the approach to other concrete properties, the most practical way of determining the effect of new constituent materials on early-age shrinkage is through standard tests. A review of the literature has shown, however, that a reliable method for measuring early-age shrinkage does not exist. This paper describes the development of a linear measurement test method for determining the early-age shrinkage of concrete.

## Review of selected published test methods

A detailed review of selected published shrinkage and shrinkage-cracking test methods was undertaken to examine the developments in test methodologies for measuring shrinkage and shrinkage related cracking. An initial review of test methods found that methodologies could be grouped into unrestrained and restrained shrinkage test methods.

---

\* Concrete Technology Unit, Division of Civil Engineering, University of Dundee, UK

† BRE Centre for Innovative Construction Materials, Department of Architecture and Civil Engineering, University of Bath, UK

(MACR D-08-00004) Paper received 11 December 2007; last revised 18 March 2008; accepted 7 May 2008

*Unrestrained shrinkage test methods*

Table 1 details the main test methods which have focused on unrestrained shrinkage in concrete. The tests were based on the use of prism or slab specimens and although initially focused on mortar, they have been further developed to investigate concrete. The main principle of these test methods was to measure the movement of embedded studs or metal plates using dial gauges<sup>14</sup> or linear variable displacement transformers (LVDTs).<sup>16,17</sup> More recently developed methods not only measure horizontal movement, but also vertical settlement,<sup>18,19</sup> although the repeatability and precision of the methods are unknown.

*Restrained shrinkage test methods*

Restrained shrinkage test methods have focused on measurements of shrinkage-related cracking rather than the shrinkage mechanism itself. Test methods have primarily used ring-shaped specimens (Table 2), slab specimens (Table 3) or prism specimens (Table 4). In some cases, tests have been carried out on mortar;<sup>10</sup> however most have focused on shrinkage cracking in concrete. Some methods measured shrinkage strains<sup>21,23</sup> whereas others inferred shrinkage from crack areas,<sup>12</sup> crack lengths and widths,<sup>8,23,24</sup> time to crack initiation<sup>13</sup> and crack image analysis.<sup>15</sup> In all cases, however, the precision and repeatability of the test methods is unknown.

**Development of an unrestrained linear test method**

The literature review revealed the need for a reliable test method that could be used to (a) determine the effects of constituent materials and (b) examine the effects of varying the test conditions, on early-age shrinkage. The study focused on the development of an unrestrained linear shrinkage test method that would determine early-age shrinkage as a combination of plastic and autogenous shrinkage. It was decided that for simplicity only linear measurements were necessary since on the basis of Power's<sup>25</sup> fundamental concept of early-age shrinkage the magnitude and duration of vertical shrinkage are very small when compared to length changes.

Test apparatus developed for a previous study (Private Communication, B. Partridge, 2006) on micro-strain in cement pastes, liquors and sludges was adopted and modified for use as a tool to measure early shrinkage strains in concrete. The test apparatus used are shown in Fig. 1. A triangular steel mould of dimensions, 380 × 110 × 50 mm was used, as shown in Fig. 2. The steel mould had a fixed-end and a moveable stop-end with steel pins to ensure good contact with the concrete. A triangular mould was chosen to reduce the surface area of the fresh concrete and hence reduce

friction effects between the mould and concrete, and also to reduce the potential for eccentricity within the longitudinal specimen. Movement owing to shrinkage was measured using a LVDT with an accuracy of 0.15 μm. Two moulds were used for each test and the mean shrinkage taken as the result.

The test method was carried out in sequential steps as shown in Fig. 3.

- (a) The triangular section moulds were prepared using silicone and oil to reduce the friction between mould and the concrete.
- (b) The inner face of the mould, which is in contact with the apex of the inverted triangle, was sealed with grease to prevent any mortar leakage and reduce friction on the triangular wedge.
- (c) A stainless steel insert was used to key the test material to the stop-end of the mould and the LVDT was placed to ensure constant contact with the tip of the steel insert.
- (d) The fresh concrete was placed into the mould and lightly compacted using a vibration table for 15 s.
- (e) The steel plate which rests on the movable end was removed by loosening the screws, before clamping screws were removed.
- (f) Once the test material had achieved sufficient stiffness (typically after 5–15 min), the clamping screws on the stop-end were released and the shrinkage of the material was continuously measured by a data logger attached to the LVDT bearing directly on the stop-end.
- (g) Tests were carried out for 10 h, and length change was measured every 10 s.

**Materials and mix proportions for experimental study**

The experimental programme was split into two main phases. In the first phase the test method was examined for single operator repeatability under standard laboratory conditions. The second phase consisted of examining the sensitivity of the test method to changes in environmental conditions namely temperature and evaporation rate.

*Constituent materials and mix proportions*

A single supply of class 42.5N CEM I conforming to BS EN 197-1<sup>26</sup> was used. Natural sand (0/4 mm) of medium grading (MP) was used as fine aggregate, and 4/10 mm gravel aggregates were used as coarse aggregate throughout the study. All aggregates conformed to BS EN 12620.<sup>27</sup> The chemical and physical composition of CEM I are given in Tables 5 and 6 respectively. Aggregate properties are given in Table 7. A single concrete mix was used to determine repeatability and the effect of environmental conditions on early-age shrinkage. The mix was designed using Building Research Establishment (BRE) mix design method<sup>34</sup> for a

Table 1. Review of unrestrained shrinkage test methods

Reference	Unrestrained shrinkage tests: prism methods			Advantages	Disadvantages
	Specimen	Environmental conditions	Measurement method		
Ravina and Shalon (1968) <sup>7</sup>	Mortar prism 70 × 70 × 280 mm	Temperature: 30°C RH: 35% Wind: 20 km/h	Dial gauges mounted on holders kept in contact with ends of studs, inserted in mortar.	Early-age shrinkage magnitudes were measured.	Accuracy unknown with manual readings. Aggregate restraint not known. Repeatability not given.
Cabrera <i>et al.</i> (1992) <sup>16</sup>	Concrete prism 150 × 150 × 710 mm	Temperature: 35 ± 1°C RH: 50 ± 5% Wind: 12.6 km/h	Shrinkage measurement carried out continuously by movement of studs penetrating into the concrete. Capillary pressure measured using plastic hoses connected to pressure transducer.	Early-age shrinkage magnitudes were measured. LVDT and pressure transducers were connected to PC for making measurements.	Aggregate restraint on the moving studs might affect shrinkage reading.  Repeatability not given.
Filho and Sanjuan (1999) <sup>14</sup>	Mortar prism 15 × 15 × 1200 mm	Temperature: 40°C RH: Unknown Wind: 1.8 km/h	Shrinkage measured using dial gauge extensometer with an accuracy of 0.01 mm, located on two steel plates connected to each other by means of a steel rod.	Early-age shrinkage magnitudes were measured.	The effect of aggregate on plastic shrinkage was not measured. Repeatability of results was not shown.
Almusallam (2001) <sup>17</sup>	Concrete slab 915 × 915 × 51 mm	Temperature: 30–45°C, RH: 25–95% Wind: 0–20 km/h	Shrinkage measured continuously using LVTDs and recorded using data acquisition system. LVDTs were attached to studs on four sides of the specimen which were embedded to half the depth of the specimen.	Early-age shrinkage magnitudes were measured. Surface area to volume ratio simulated actual condition. Non-absorptive forms were used for moulds.	Repeatability not given. Aggregate restraint on the moving studs might affect shrinkage reading.
Turcyy and Loukili (2003) <sup>18</sup>	Concrete prism, 70 × 70 × 280 mm	Temperature: 20 ± 1°C RH: 50 ± 5% Wind: Not tested	Movement of two reflecting plates measured by laser sensors. Laser sensor also used to measure settlement.	Early-age shrinkage magnitudes were measured. Horizontal and vertical shrinkages measured.	Repeatability not given.
Holt (2001) <sup>19</sup>	Concrete slab 270 × 270 × 100 mm	Temperature: 20°C RH: 40% Wind: Not tested	Horizontal shrinkage was measured continuously with LVDTs in contact with two metal plates embedded in concrete. Vertical settlement and capillary pressure measured with LVDT and pressure transducers.	Early-age shrinkage magnitudes were measured. A relationship between horizontal shrinkage, settlement and capillary pressure can be established.	Aggregate restraint on steel plates might affect shrinkage reading.  Effect of wind-velocity not known.

Table 2. Review of restrained shrinkage tests with ring shaped specimens

Reference	Restrained shrinkage tests: ring methods			Advantages	Disadvantages
	Specimen	Environmental conditions	Measurement method		
Dahl (1988) <sup>9</sup>	Ring <i>Mortar and Concrete</i> 280 (inner dia) × 580 (outer dia) × 80 (height) mm	Temperature: 20°C RH: 40% Wind: 14.4 km/h	Shrinkage measured in terms of total crack widths after drying in 24 h, manually by visual observations.	Restraint provided with steel ribs. Eccentricity avoided owing to ring.	Magnitude of shrinkage not known. Repeatability not given.
Padron and Zollo (1990) <sup>11</sup>	Square slab with ring core  <i>Mortar</i> Slab: 300 × 300 × 12.6 mm Ring: 114 mm <i>Concrete</i> Slab: 300 × 300 × 25.4 mm Ring: 140 mm	Temperature: 31°C RH: 50% Wind: 10 km/h (mortar) 22 km/h (concrete)	Shrinkage measured in terms of initiation of cracks and total crack areas. (the length and average width were expressed as total crack area) using a crack comparator.	Restraint provided with a steel ring in slab to induce cracking.	Magnitude of shrinkage not known. Repeatability not given.
Filho and Sanjuan (1999) <sup>14</sup>	Ring sample with cube core  <i>Mortar</i> Ring: 150 Ø × 50 mm Cube: 70 × 70 mm	Temperature: 40°C RH: Unknown Wind: 1.4 km/h	Shrinkage was measured in terms of crack widths.	Restraint provided with a cube to induce cracking.	Magnitude of shrinkage not known. Repeatability not given.

Table 3. Review of restrained shrinkage tests with slab-shaped specimens

Reference	Restrained shrinkage tests: slab methods			Advantages	Disadvantages
	Specimen	Environmental conditions	Measurement method		
Ravina and Shalon (1968) <sup>7</sup>	Concrete slab 650 × 800 × 70 mm	Temperature: Unknown RH: Unknown Wind: Unknown	Shrinkage measured in terms of total crack widths. Crack widths measured on cores drilled from the specimen.	Restraint was provided with barbed wire to induce cracks.	Cracks areas measured were approximate. Magnitude of shrinkage not known. Repeatability not given.
Kraai (1985) <sup>8</sup>	Concrete slab 1200 × 1200 × 20 mm Mortar slab 610 × 910 × 20 mm	Temperature: Unknown RH: Unknown Wind: 36.43 km/h	Crack lengths and crack widths were recorded manually after 24 h.	Restraint was provided along the perimeter to induce cracks.	Crack areas measured were approximate. Magnitude of shrinkage not known. Repeatability not given.
Shaeles and Hover (1988) <sup>10</sup>	Mortar slab 610 × 910 × 20 mm	Temperature: 25–35°C RH: 10–25% Wind: 11–13 km/h	Shrinkage inferred from crack areas by measuring crack lengths and widths.	Non-absorptive moulds were used to generate reliable results.	Crack areas measured were approximate. Magnitude of shrinkage not known.
Balaguru (1994) <sup>12</sup>	Concrete slab 600 × 900 × 19 mm	Temperature: 22 ± 1°C, RH: 50 ± 3% Wind: 51.2 km/h	Shrinkage inferred from crack areas by measuring crack lengths and widths.	Non-absorptive moulds were used to minimise friction. Stress risers simulate the reinforcement on the slabs cast on site.	Crack areas measured were approximate. Magnitude of shrinkage not known. Repeatability not given.
Yokoyama <i>et al.</i> (1994) <sup>13</sup>	Concrete slab 600 × 600 × 50 mm	Temperature: 30°C, RH: 60% Wind: 30 km/h	Shrinkage inferred from crack lengths and crack widths.	Restraint is provided on all sides with steel stud bolts to induce cracks.	Crack areas measured were approximate. Magnitude of shrinkage not known. Repeatability not given.
Qi <i>et al.</i> (2003) <sup>15</sup>	Concrete slab 508 × 254 × 76 mm	Temperature: 38 ± 1°C, RH: 50 ± 2% Wind: 24 km/h	Image analysis at 24 h to measure cracks areas. Reflected laser beam used to determine the settlement of concrete	Image analysis is accurate in measuring the crack areas and widths. Stress risers provided to induce cracks.	Magnitude of shrinkage not known. Repeatability not given.

Table 4. Review of restrained shrinkage tests with prism shaped specimens

Reference	Restrained shrinkage test: prism methods			Advantages	Disadvantages
	Specimen	Environmental conditions	Measurement method		
Paillere <i>et al.</i> (1989) <sup>20</sup>	Concrete prism 85 × 120 × 1500 mm	Temperature: Not known RH: Not known Wind: NA	Shrinkage measured in terms of the load required to avoid a specific change in length. The force applied recorded using a dynamometer.	Restraint provided on one side of the specimen with fixed head as the shrinkage was measured on free head on the other end.	Repeatability not given.
Bloom and Bentur (1995) <sup>21</sup>	Concrete prism 40 × 40 × 1000 mm	Temperature: 40°C RH:45% Wind: Not tested	Shrinkage measured in terms of load required to avoid a specific change in length. The load developed under fully restrained condition was monitored by a load cell.	Restraint provided on one end of the specimen with fixed grip as the shrinkage was measured on free grip allowed to move on the other end.	Repeatability not given.
Banthia <i>et al.</i> (1996) <sup>22</sup>	Prism Overlay: Concrete 100 × 100 × 100 mm Substrate: Concrete 40 × 100 × 100 mm	Temperature: 38 ± 1°C RH: 5 ± 2% Wind: Unknown	Shrinkage inferred from crack areas by measuring lengths and widths of cracks with microscope.	Restraint provided with rough substrate to induce cracks.	Magnitude of shrinkage was not known. Crack areas measured were approximate. Repeatability not given.
Mora <i>et al.</i> (2001) <sup>23</sup>	Concrete prism 600 × 150 × 150 mm	Temperature: 44 ± 1°C, RH:25 ± 5% Wind: 40 ± 2 km/h	Shrinkage was expressed in terms of the deformation over the central riser and crack widths.	Restraint provided with stress risers and anchor bars to induce cracks.	Set-up used for measuring deformation was not precise. Repeatability not given.
Naaman <i>et al.</i> (2005) <sup>24</sup>	Concrete prism 1016 × 76.2 × 38.1 mm	Temperature: 35°C to 41°C RH: 22.5 ± 2.5% Wind: Unknown	Shrinkage inferred from crack areas by measuring crack lengths and widths with the help of crack width comparator, handheld microscope and magnifying glass.	Restraint provided with grooved substrate to induce cracks.	Magnitude of shrinkage was not known. Crack areas measured were approximate. Repeatability not given.
Banthia and Gupta (2006) <sup>3</sup>	Prism Overlay: Mortar 100 × 100 × 375 mm Substrate: Concrete 40 × 95 × 325 mm	Temperature: 38 ± 1°C RH: 5 ± 2% Wind: Not tested	Shrinkage inferred from crack areas by measuring lengths and widths of cracks with microscope of accuracy 0.01 mm.	Restraint provided with protuberances on substrate to induce cracks.	Magnitude of shrinkage unknown. Crack areas measured were approximate. Repeatability not given.



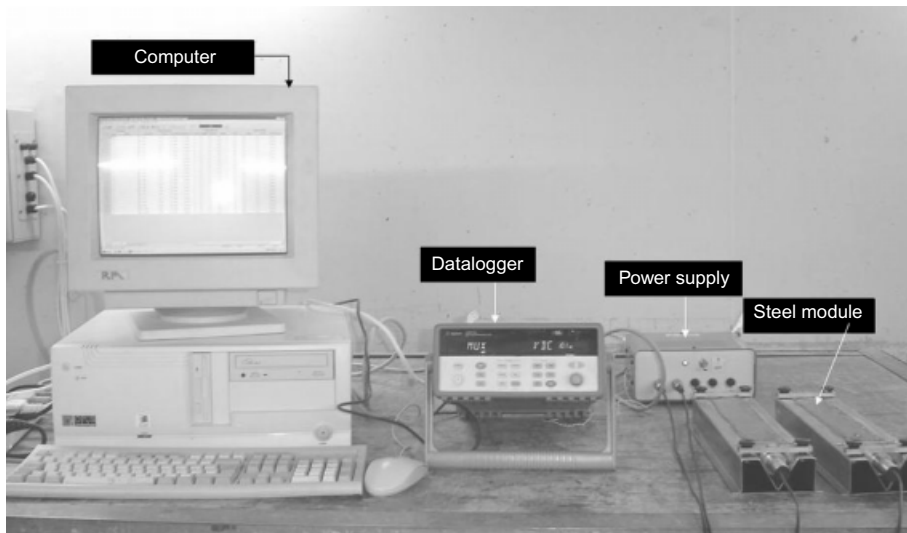

Fig. 1. Experimental set-up of linear test method for early-age shrinkage measurement

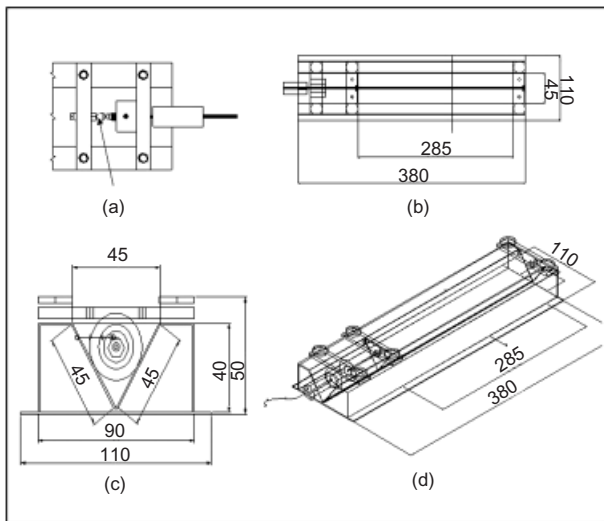

Fig. 2. Dimensions and view of the linear test mould: (a) contact of LVDT and steel insert; (b) plan; (c) elevation; (d) isometric view. All dimensions in mm

water/cement (w/c) ratio of 0.5. The mix proportions are shown with selected concrete properties in Table 8.

### Single operator repeatability study of linear test method

The single operator repeatability of the test method was determined by testing ten nominally similar batches of concrete under the same laboratory conditions ( $20 \pm 2^\circ\text{C}$  and  $50 \pm 5\%$  RH.). Two prisms were tested for each batch and the shrinkage expressed as the mean. Table 9 shows the analysis of the results for the two single prism specimens and the calculated mean values. Although the shrinkage was continuously measured, the results expressed here are measurements taken at 2, 4, 6, 8 and 10 h to investigate the variation in repeatability with time. The results show that although the coefficient of variation is high in the early

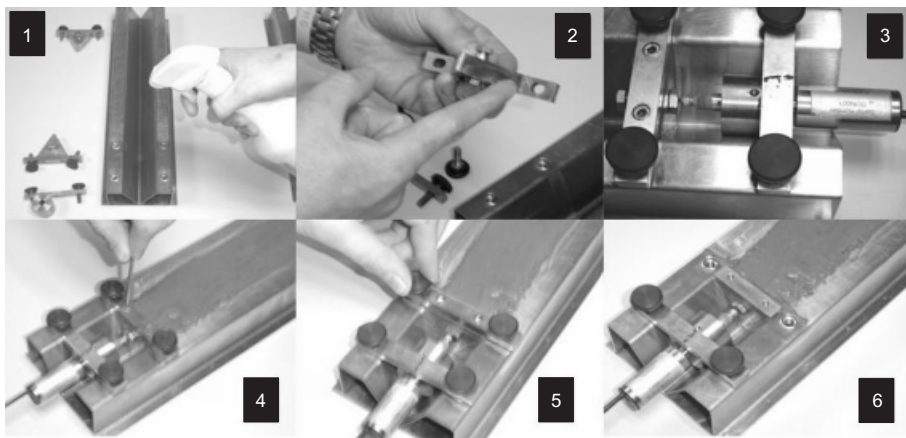

Fig. 3. Sequential steps for the linear test method: (1) application of lubricating oil to mould, (2) application of mould oil to moveable stop end, (3) fixing of LVDT to moveable stop end, (4) and (5) releasing moveable stop end, (6) commencement of testing period.



Table 5. Bulk oxide composition of CEM I (% by mass), tested in accordance with BS EN 196-2:2005<sup>28</sup>

SiO <sub>2</sub>	Al <sub>2</sub> O <sub>3</sub>	Fe <sub>2</sub> O <sub>3</sub>	CaO	MgO	SO <sub>3</sub>	S <sup>2-</sup>	Na <sub>2</sub> O	K <sub>2</sub> O	Other oxides
20.4	5.1	2.7	63.8	2.7	3.3	-	0.4	0.7	1.4

Table 6. Physical composition of cement

Physical properties	
Particle density*	3.0 g/cm <sup>3</sup>
Fineness-Blaine†	350 m <sup>2</sup> /kg
Setting time‡	02h:05 min
28-day strength§	62.0 N/mm <sup>2</sup>
Loss on ignition¶	1.0 %

\* BS EN 1097-7,<sup>29</sup> † BS EN 196-6,<sup>30</sup> ‡ BS EN 196-3,<sup>31</sup> § BS EN 196-1,<sup>32</sup> ¶ BS EN 196-2<sup>28</sup>

Table 7. Aggregate properties

Aggregate type	Particle density:*	Water absorption:*
	g/cm <sup>3</sup>	%
Natural sand (0/4 mm)	2.6	0.45
Natural gravel (4/10 mm)	2.5	1.20

\* Tested in accordance with BS EN 1097-6:2000<sup>33</sup>

stages of the test ( $V = 44\%$ ), it reduced as the test proceeds to up to 10 h. This is primarily a function of the magnitude of the shrinkage at the early stages with small variations being magnified. At 10 h the standard deviation across the ten test mixes was 0.024 mm/m and 0.021 mm/m for the two test specimens. The mean coefficient of variation across the two specimens was 4.8%.

Analysis of the repeatability limit,  $r$  of the test method in accordance with ISO 5725-2<sup>38</sup> showed that at 10 h the test had a repeatability limit of 0.056 mm/m, equating to a percentage repeatability of 13.5% at a 95% confidence level. The repeatability limits were deemed satisfactory and showed the test had the potential to be used as a tool for examining the early-age shrinkage of concrete.

Table 8. Mix proportions

Mix	w/c	Mix proportions: kg/m <sup>3</sup>				Total* fines: kg/m <sup>3</sup>	Slump†: mm	Plastic density‡: kg/m <sup>3</sup>	28 day cube strength§: N/mm <sup>2</sup>
		CEM I	Water	Aggregates					
				0/4 mm	4/10 mm				
PC	0.5	410	205	745	990	415	80	2375	55

\* Fines = particles < 63 µm sieve as defined in BS EN 12620<sup>27</sup>

† BS EN 12350-2,<sup>35</sup> ‡ BS EN 12350-6,<sup>36</sup> § BS EN 12390-3<sup>37</sup>

## Sensitivity of linear test method to environmental conditions

The sensitivity of the test method to changes in environmental conditions was examined by conducting early-age shrinkage measurements for 10 h in the following three exposure environments (Fig. 4)

- Exposure environment 1: Standard laboratory conditions,  $20 \pm 2^\circ\text{C}$  and  $50 \pm 5\%$  RH
- Exposure environment 2: Standard laboratory temperature  $20 \pm 2^\circ\text{C}$ , with completely sealed conditions,  $>95\%$  RH
- Exposure environment 3: Increased temperature  $40 \pm 2^\circ\text{C}$ ,  $10 \pm 5\%$  RH, and exposure to a wind velocity of  $7.5 \pm 0.5$  km/h.

### Monitoring of environmental conditions

Bleeding of the concrete was measured on a fresh concrete sample in a cylindrical container of 250 mm diameter  $\times$  200 mm in accordance with BS EN 480-4.<sup>39</sup> The evaporation rates within the three test environments were monitored by constantly measuring the mass change of a 100 mm diameter cylindrical container containing deionised/distilled water with a free water surface of area 7854 mm<sup>2</sup>. Measurement of evaporation rate from the concrete surface was not measured due to doubts over the accuracy of measuring the true exposed surface area of the fresh concrete. The wind velocity of the fans was measured using a digital anemometer and temperature and relative humidity measured using a digital hygro-thermometer.

### Sensitivity results

The results of the tests carried out in three exposure conditions are shown in Fig. 5. The tests showed that there was a significant difference in the magnitudes of early shrinkage at 10 h ranging from 0.03 mm/m in

Table 9. Single operator repeatability results of unrestrained linear test method

Test number	Early-age shrinkage: mm/m														
	Prism 1					Prism 2					Mean				
	2 h	4 h	6 h	8 h	10 h	2 h	4 h	6 h	8 h	10 h	2 h	4 h	6 h	8 h	10 h
1	0.273	0.405	0.420	0.423	0.433	0.232	0.385	0.400	0.404	0.419	0.253	0.395	0.410	0.414	0.426
2	0.368	0.424	0.444	0.447	0.472	0.385	0.412	0.430	0.433	0.433	0.377	0.418	0.437	0.440	0.453
3	0.334	0.391	0.395	0.404	0.404	0.351	0.410	0.415	0.421	0.428	0.343	0.401	0.405	0.413	0.416
4	0.321	0.400	0.411	0.413	0.425	0.340	0.380	0.378	0.378	0.395	0.331	0.390	0.395	0.396	0.410
5	0.358	0.408	0.420	0.421	0.424	0.332	0.385	0.400	0.404	0.421	0.345	0.397	0.410	0.413	0.423
6	0.310	0.360	0.401	0.410	0.425	0.290	0.343	0.380	0.413	0.408	0.300	0.352	0.391	0.412	0.417
7	0.229	0.288	0.372	0.384	0.400	0.257	0.302	0.374	0.380	0.380	0.243	0.295	0.373	0.382	0.390
8	0.281	0.320	0.359	0.394	0.394	0.296	0.340	0.377	0.404	0.410	0.289	0.330	0.368	0.399	0.402
9	0.280	0.355	0.365	0.360	0.393	0.304	0.338	0.350	0.369	0.373	0.292	0.347	0.358	0.365	0.383
10	0.240	0.302	0.368	0.395	0.419	0.260	0.345	0.385	0.425	0.431	0.250	0.324	0.377	0.410	0.425
Maximum: mm/m	0.368	0.424	0.444	0.447	0.472	0.385	0.412	0.430	0.433	0.433	0.377	0.418	0.437	0.440	0.453
Minimum: mm/m	0.229	0.288	0.359	0.360	0.393	0.232	0.302	0.350	0.369	0.373	0.243	0.295	0.358	0.365	0.383
Mean: mm/m	0.299	0.365	0.396	0.405	0.419	0.305	0.364	0.389	0.403	0.410	0.302	0.365	0.392	0.404	0.414
$\sigma_r$ : mm/m	0.047	0.048	0.029	0.024	0.024	0.048	0.036	0.023	0.021	0.021	0.046	0.041	0.024	0.020	0.020
$V$ : %	15.7	13.2	7.2	5.9	5.6	15.6	9.8	5.9	5.3	5.1	15.1	11.2	6.1	5.1	4.8
$r^1$ : mm/m	0.132	0.134	0.081	0.067	0.067	0.134	0.101	0.064	0.059	0.059	0.129	0.115	0.067	0.056	0.056
$r^*$ : %	44.0	36.8	20.5	16.6	16.0	44.1	27.7	16.6	14.6	14.3	42.6	31.5	17.1	13.9	13.5

$r^1 = 2.8\sigma_r$  where  $\sigma_r$  is the standard deviation under repeatability conditions<sup>38</sup>

\* Percentage repeatability limit ( $r$  expressed as a percentage of the mean)

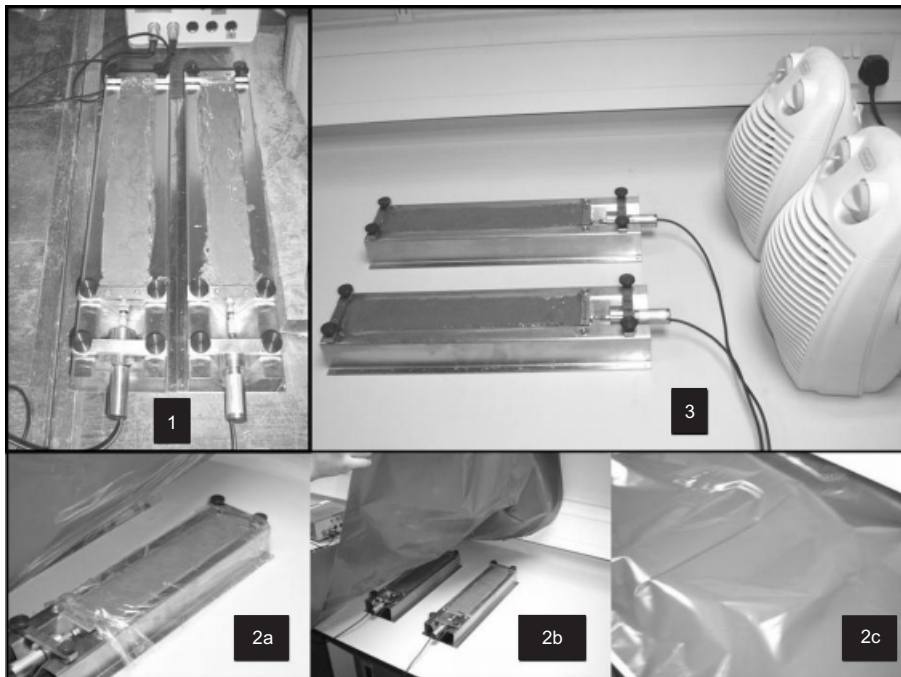

Fig. 4. Environmental exposure conditions (1) laboratory conditions, (2 a, b, c) sealed conditions, (3) wind exposure and increased temperature

sealed conditions to 0.93 mm/m in conditions with increased temperature and exposure to wind. In exposure environment 1, the evaporation rate (0.20 kg/m<sup>2</sup>/h) was slightly higher than the bleeding rate (0.15 kg/m<sup>2</sup>/h) and therefore the early-age shrinkage was attributed mainly to plastic shrinkage. The shrinkage in exposure

environment 3 was attributed to autogenous shrinkage as the evaporation rate was negligible compared to the bleeding rate. In exposure environment 3, the effects were attributed to plastic shrinkage effects as the evaporation rate was increased owing to the wind velocity and temperature.

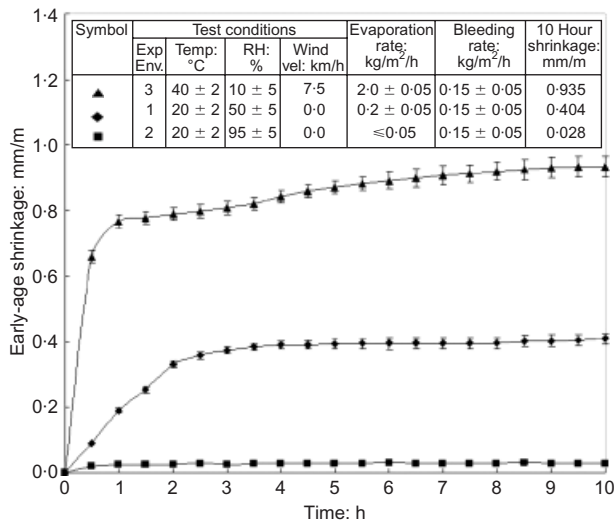

Fig. 5. Early-age shrinkage behaviour of Portland cement concrete for different test conditions

## Conclusions

The work presented here reviewed current test methods for measuring early-age shrinkage of concrete and developed a new linear test method. The test method has sufficient sensitivity to assess the effects of varying the environmental conditions, and the repeatability is such that it will be able to assess the effects of different types of constituent materials on the shrinkage of concrete. Conclusions that can be drawn from the work are outlined below.

- (a) A review of previous and current test methods revealed the need for a repeatable test method. Previous test methods had either focussed on shrinkage cracking or unrestrained shrinkage, although in most cases the repeatability of the test methods were unknown.
- (b) The new unrestrained test method was based on linear shrinkage, as this was more significant than the effects of horizontal movement, and used a triangular mould to minimise variability owing to eccentricity. A single operator repeatability study showed the method had a coefficient of variation of 4.5% and a repeatability of 13.5% indicating its potential for use as a tool for reliably measuring early-age shrinkage.
- (c) The test was shown to be sensitive to changes in environmental conditions and was able to detect and measure changes in shrinkage owing to variations in temperature, relative humidity and wind velocity.

## Acknowledgements

Professor Tom Harrison (Quarry Products Association), Roy Jones (BASF Construction Chemicals) and Paul Livesey (Castle Cement) are acknowledged for

their financial support to this project. Wexham Developments are thanked for their advice during the development of this test method.

## References

1. NEVILLE A. M. *Properties of Concrete*, 4<sup>th</sup> edn. Pearson Education, London, 2003.
2. BAYASI Z. and MCINTYRE M. Application of fibrillated polypropylene fibres for restraint of plastic shrinkage cracking in silica fume concrete. *ACI Materials Journal*, 2002, **99**, No. 4, 337–344.
3. BANTHIA N. and GUPTA R. Influence of polypropylene fiber geometry on plastic shrinkage cracking in concrete. *Cement and Concrete Research*, 2006, **36**, No. 7, 1263–1267.
4. WITTMANN F. H. On the action of capillary pressure in fresh concrete. *Cement and Concrete Research*, 1976, **6**, No. 1, 49–56.
5. JENSEN O. M. and HANSEN P. F. Autogenous deformation and RH change in perspective. *Cement and Concrete Research*, 2001, **31**, No. 12, 1859–1865.
6. JAPAN CONCRETE INSTITUTE. Technical Report on Autogenous Shrinkage of Concrete, *Proceedings of International Workshop AUTOSHRINK'98*, June 1998, Hiroshima, pp. 1–67.
7. RAVINA D. and SHALON R. Plastic shrinkage cracking. *ACI Journal Proceedings*, 1968, **65**, No. 4, 282–292.
8. KRAAI P. P. Proposed test to determine the cracking potential due to drying shrinkage of concrete. *Concrete Construction*, 1985, **30**, No. 9, 775–778.
9. DAHL P. A. Cracking tendency of Krenit fiber reinforced concrete exposed to plastic shrinkage. Trondheim, Norwegian Institute of Technology, 1988, pp. 1–25. SINTEF Report STF65 A88033.
10. SHAELES C. A. and HOVER K. C. Influence of mix proportions and construction operations on plastic shrinkage cracking in thin slabs. *ACI Materials Journal*, 1988, **85**, No. 6, 495–504.
11. PADRON I. and ZOLLO R. F. Effect of synthetic fibres on volume stability and cracking of Portland cement concrete and mortar. *ACI Materials Journal*, 1990, **87**, No. 4, 327–332.
12. BALAGURU P. N. Contribution of fibres to crack reduction of cement composites during the initial and final setting period. *ACI Materials Journal*, 1994, **91**, No. 3, 280–288.
13. YOKOYAMA K., HIRAIISHI S., KASAI Y. and KISHITANI K. *Shrinkage and Cracking of High-Strength Concrete and Flowing Concrete at Early Ages*. American Concrete Institute, Detroit, 1994, pp. 243–258. ACI SP-148
14. FILHO R. D. T. and SANJUÁN M. A. Effect of low modulus sisal and polypropylene fibre on the free and restrained shrinkage of mortars at early age. *Cement and Concrete Research*, 1999, **29**, No. 10, 1597–1604.
15. QI C., WEISS J. and OLEK J. Characterization of plastic shrinkage cracking in fiber reinforced concrete using image analysis and a modified Weibull function. *RILEM Materials and Structures*, 2003, **36**, No. 260, 386–395.
16. CABRERA J. G., CUSENS A. R. and BROOKES-WANG Y. Effect of super plasticizers on the plastic shrinkage of concrete. *Magazine of Concrete Research*, 1992, **44**, No. 160, 149–161.
17. ALMUSALLAM A. A. Effect of environmental conditions on the properties of fresh and hardened concrete. *Cement and Concrete Composites*, 2001, **23**, No. 4/5, 353–361.
18. TURCRY P. and LOUKILI A. A study of plastic shrinkage of self-compacting concrete. *Proceedings of the 3rd International RILEM Symposium Reykjavik, Iceland* (WALLEVIK O. and I. NIELSSON I. (eds). RILEM Publications, 2003, **1**, 576–585.
19. HOLT E. Contribution of mixture design to chemical and autogenous shrinkage of concrete at early ages. *Cement and Concrete Research*, 2005, **35**, No. 3, 464–472.
20. PAILLIERE A. M., BUIL M. and SERRANO J. J. Effect of fibre  
*Magazine of Concrete Research*, 2008, **60**, No. 10

- addition on the autogeneous shrinkage of silica fume concrete. *ACI Materials Journal*, 1989, **86**, No. 2, 139–144.
21. BLOOM R. and BENTUR A. Free and restrained shrinkage of normal and high-strength concretes. *ACI Materials Journal*, 1995, **92**, No. 2, 211–217.
  22. BANTHIA N., YAN C. and MINDESS S., Restraint shrinkage cracking in fibre reinforced concrete: a novel test technique. *Cement and Concrete Research*, 1996, **26**, No. 1, 9–14.
  23. MORA J., MARTIN M. A., GETTU R. and AGUADO A. Study of plastic shrinkage cracking in concrete and the influence of fibers and a shrinkage reducing admixture. *L'Industria Italiana del Cemento*, 2001, **71**, No. 11, 828–837.
  24. NAAMAN A. E., WONGTANAKITCHAROEN T. W. and HAUSER G. Influence of different fibers on plastic shrinkage cracking of concrete. *ACI Materials Journal*, 2005, **102**, No. 1, 49–61.
  25. POWERS T. C. *The Properties of Fresh Concrete*. Wiley, New York, 1968.
  26. BRITISH STANDARDS INSTITUTION. *BS EN 197-1: 2000. Cement Composition, Specifications and Conformity Criteria for Common Cements*. BSI, London, 2000.
  27. BRITISH STANDARDS INSTITUTION. *BS EN 12620: 2002. Aggregates for Concrete*. BSI, London, 2002.
  28. BRITISH STANDARDS INSTITUTION. *BS EN 196-2: 2005. Methods of Testing Cement. Chemical Analysis of Cement*. BSI, London, 2005.
  29. BRITISH STANDARDS INSTITUTION. *BS EN 1097-7: 1999. Tests for Mechanical and Physical Properties of Aggregates. Determination of the Particle Density of Filler. Pycnometer Method*. BSI, London, 1999.
  30. BRITISH STANDARDS INSTITUTION. *BS EN 196-6: 1992. Methods of Testing Cement: Determination of Fineness*. BSI, London, 1992.
  31. BRITISH STANDARDS INSTITUTION. *BS EN 196-3: 2005. Methods of Testing Cement. Determination of Setting Time and Soundness*. BSI, London, 2005.
  32. BRITISH STANDARDS INSTITUTION. *BS EN 196-1: 2005. Methods of Testing Cement. Determination of Strength*. BSI, London, 2005.
  33. BRITISH STANDARDS INSTITUTION. *BS EN 1097-6: 2000. Tests for Mechanical and Physical Properties of Aggregates. Determination of Particle Density and Water Absorption*. BSI, London, 2000.
  34. TEYCHENNE D. C., FRANKLIN R. E., ERNTROY H. C. and MARSH B. K. *Design of Normal Concrete Mixes*, 2<sup>nd</sup> ed. Building Research Establishment, London, 1988.
  35. BRITISH STANDARDS INSTITUTION. *BS EN 12350-2: 2000. Testing Fresh Concrete: Slump Test*. BSI, London, 2000.
  36. BRITISH STANDARDS INSTITUTION. *BS EN 12350-6: 2000. Testing fresh concrete. Density*. BSI, London, 2000.
  37. BRITISH STANDARDS INSTITUTION. *BS EN 12390-3: 2002. Testing Hardened Concrete. Compressive Strength of Test Specimens*. BSI, London, 2002.
  38. INTERNATIONAL STANDARDS ORGANISATION. *ISO 5725-2, Accuracy (trueness and precision) of measurement methods and results - Part 2: Basic method for the determination of repeatability and reproducibility of a standard measurement method*, 1<sup>st</sup> edn. ISO, Geneva, 1994.
  39. BRITISH STANDARDS INSTITUTION. *BS EN 480-4, 2005. Admixtures for Concrete, Mortar and Grout. Test Methods. Determination of Bleeding of Concrete*. BSI, London, 2005.

**Discussion contributions on this paper should reach the editor by 1 June 2009**