



Citation for published version:

Churchill, SM, Trewartha, G, Bezodis, IN & Salo, AIT 2016, 'Force production during maximal effort bend sprinting: theory vs reality', *Scandinavian Journal of Medicine and Science in Sports*, vol. 26, pp. 1171-1179. <https://doi.org/10.1111/sms.12559>

DOI:

[10.1111/sms.12559](https://doi.org/10.1111/sms.12559)

Publication date:

2016

Document Version

Peer reviewed version

[Link to publication](#)

University of Bath

Alternative formats

If you require this document in an alternative format, please contact:
openaccess@bath.ac.uk

General rights

Copyright and moral rights for the publications made accessible in the public portal are retained by the authors and/or other copyright owners and it is a condition of accessing publications that users recognise and abide by the legal requirements associated with these rights.

Take down policy

If you believe that this document breaches copyright please contact us providing details, and we will remove access to the work immediately and investigate your claim.

Force production during maximal effort bend sprinting: theory versus reality

SARAH M. CHURCHILL^{1,2}, GRANT TREWARTHA¹,

IAN N. BEZODIS³ AND AKI I.T. SALO^{1, a}

¹) Sport, Health and Exercise Science, University of Bath, Bath, UK

²) Academy of Sport and Physical Activity, Sheffield Hallam University, Sheffield, UK

³) Cardiff School of Sport, Cardiff Metropolitan University, Cardiff, UK

Running Head: Force production during bend sprinting

^a Corresponding author:

Dr Aki I. T. Salo

Sport, Health and Exercise Science

Applied Biomechanics Suite 1.309

University of Bath

BATH, BA2 7AY

UNITED KINGDOM

Tel. +44-1225-383569

Email: A.Salo@bath.ac.uk

1 Force production during maximal effort bend sprinting: theory 2 versus reality

3 ABSTRACT

4 This study investigated whether the ‘constant limb force hypothesis’ can be applied to bend
5 sprinting on an athletics track and to understand how force production influences
6 performance on the bend compared with the straight. Force and three-dimensional video
7 analyses were conducted on seven competitive athletes during maximal effort sprinting on the
8 bend (radius 37.72 m) and straight. Left step mean peak vertical and resultant force decreased
9 significantly by 0.37 BW and 0.21 BW, respectively, on the bend compared with the straight.
10 Right step force production was not compromised in the same way, and some athletes
11 demonstrated substantial increases in these variables on the bend. More inward impulse
12 during left (39.9 ± 6.5 Ns) than right foot contact (24.7 ± 5.8 Ns) resulted in 1.6° more
13 turning during the left step on the bend. There was a 2.3% decrease in velocity from straight
14 to bend for both steps. The constant limb force hypothesis is not entirely valid for maximal
15 effort sprinting on the bend. Also, the force requirements of bend sprinting are considerably
16 different to straight-line sprinting and are asymmetrical in nature. Overall, bend-specific
17 strength and technique training may improve performance during this portion of 200 m and
18 400 m races.

19
20 **Keywords:** Running gait, Mediolateral impulse, Limb asymmetry, Track and Field, 200 m,
21 Curve, Constant limb force

22 **Introduction**

23 Force production during maximal effort sprinting on the bend, on the surfaces and at radii
24 typical of athletic sprint events, is not well understood. This is despite the fact that during
25 200 m and 400 m track and field sprint events more than 50% of the race is run on the bend
26 section of the track. Utilising information from Greene (1985) and Weyand et al. (2000),
27 Usherwood and Wilson (2006) adopted the ‘constant limb force hypothesis’ for their
28 mathematical model of bend sprinting. This model assumes that athletes running on the bend
29 would generate the same constant maximum resultant force as on the straight. Thus, with the
30 additional requirement to generate centripetal force to turn on the bend (and stay within the
31 lane), it was postulated by Usherwood and Wilson (2006) that athletes would increase the
32 time spent in ground contact in order to produce the necessary vertical and inward impulses.
33 This consequently would reduce the sprinting speed. On the other hand, Gaudet (2014), when
34 creating a mathematical model for sprinting, speculated that athletes do not apply maximum
35 force during the bend running, although the author did not provide any empirical evidence for
36 this statement.

37

38 In contrast to the above, empirical research into maximal effort sprinting on bends of very
39 small radii (1-6 m) has found athletes to be unable to achieve the resultant and vertical forces
40 on the bend that they were capable of during straight-line sprinting (Chang & Kram, 2007).
41 Even during slower running (approximately 6 m/s) on larger radii typical of an athletics track,
42 vertical force production has been observed to be reduced compared with straight-line
43 running (Hamill et al., 1987).

44

45 There is reason to believe that left and right legs may have different roles in force production
46 and in keeping the athletes on the appropriate curved path during bend sprinting. Chang and

47 Kram (2007) found that during sprinting on bends with radii of 1-6 m, the right leg produced
48 greater peak lateral forces than the left leg. In contrast, Hamill et al. (1987) found that at a
49 bend radius of 31.5 m, larger peak lateral forces were produced by the left leg than the right
50 leg when running at approximately 6 m/s. Churchill et al. (2015) reported that, during
51 maximal effort sprinting on a track bend radius of 37.72 m, more turning was achieved
52 during the left ground contact than the right. This suggests that when sprinting maximally at
53 radii typical of an athletics track, the left leg may produce greater inward force than the right
54 leg. However, empirical measurement is required to confirm this.

55

56 Although Usherwood and Wilson (2005) demonstrated that the constant limb force
57 hypothesis fails for greyhounds (limb forces increase on the bend), this theory has never been
58 appropriately and empirically tested on sprinters running on an athletics track. Thus, the main
59 aim of this study was to empirically investigate whether the constant limb force hypothesis is
60 valid in maximal effort bend sprinting. In order to test this, force production characteristics
61 were compared between bend and straight line sprinting with a view to understand how any
62 potential changes in force production contribute to changes in performance descriptors. Based
63 on the empirical literature of smaller radii running, it was hypothesised that athletes would
64 produce less maximum resultant and vertical force on the bend than the straight. The second
65 hypothesis was that more inward impulse, and thus turning, would be generated during the
66 left ground contact than the right.

67

68 **Methods**

69 *Participants*

70 Considering that all participants were required to be experienced in bend sprinting (200 m
71 and/or 400 m) and competed at national or international level, and the fact that such athletes

72 are often reluctant to take part in research (Kearney, 1999), an opportunistic sampling of
73 seven male sprinters from a limited pool of appropriate athletes volunteered for the study.
74 The mean age, mass and height of the participants were 22.6 ± 4.2 years, 70.7 ± 9.2 kg and
75 1.76 ± 0.06 m, respectively, with the mean 200 m personal best time = 22.04 ± 0.74 s (range
76 = 20.89 s to 22.90 s). The study procedures were approved by the local research ethics
77 committee and all athletes provided written informed consent.

78

79 *Data collection*

80 Athletes undertook maximal effort sprints on the bend and straight in an indoor athletics
81 centre. For the bend trials, markings were made on the track surface across the flat infield to
82 fully replicate 60 m of lane 2 of a standard outdoor track (radius: 37.72 m). Bend trials were
83 completed entirely around the bend and straight trials entirely on the straight. Two 0.90 m by
84 0.60 m force plates (9287BA, Kistler Instruments Ltd, Switzerland) operating at 1000 Hz
85 were located contiguously in an area where the bend and straight lanes overlapped (Fig. 1).
86 The force plates were isolated from the track foundations and surrounding track surface, and
87 were covered with a piece of firmly-secured synthetic track surface which was flush with the
88 rest of the track. Two video cameras (HVR-Z5E, Sony Corporation, Japan) operating at 200
89 Hz, with a shutter speed of 1/600 s, recorded a whole step starting from touchdown on the
90 force plate and finishing with the touchdown of the contralateral leg. The separation angle of
91 the two cameras' optical axes was approximately 95° (Fig. 1).

92

93 ***Fig. 1 near here***

94

95 An 18-point structure was used to calibrate a three-dimensional (3D) activity volume (6.00 m
96 long \times 1.60 m wide \times 2.00 m high). The positive y-axis of the global coordinate system

97 (GCS) was aligned with the positive y-axis of the force plates (the primary direction of travel
98 of the athlete within the activity volume), the positive x-axis was to the right and positive z-
99 axis was vertically upwards.

100

101 Athletes completed their typical competition warm up before undertaking up to six 60 m
102 maximal effort sprints to achieve one successful left step and one successful right step on the
103 bend and one successful left step and one successful right step on the straight. A step was
104 assigned as left or right based on the leg producing the force on the initial contact with the
105 force plate and for the following airborne phase. A successful trial was when the athlete's
106 foot made contact within the force plate area without any visible alteration to the step pattern.
107 All athletes achieved the required four different steps within the agreed maximum of six runs.
108 This was helped by one investigator modifying the starting location of athletes based on a
109 warm-up run and consequent trials after spotting the locations of the steps on the force plate
110 area. In order to reduce the likelihood of force plate targeting, athletes were not informed of
111 the location of the force plates, nor were they easily visible. All athletes had at least 40 m
112 run-up, before the filming area. Recovery time between trials was approximately eight
113 minutes.

114

115 *Data processing*

116 All trials were manually digitised using Vicon Motus software (Version 9.2, Vicon, Oxford,
117 UK) at a resolution of 720×576 pixels with a $2 \times$ zoom function increasing the effective
118 resolution of the screen to 1440×1152 pixels. Two sets of synchronised 20-LED displays
119 were triggered during each trial to allow the video streams and the force data to be
120 synchronised to the nearest 1 ms.

121

122 Digitised trial video clips included 10 fields before the touchdown on the force plate and 10
123 fields after the next touchdown to mitigate against end-point errors in the data conditioning
124 process (Smith, 1989). The digitised 20-point model of the human body consisted of the top
125 of the head, the joint centres of the neck (C7 level), shoulders, elbows, wrists, hips, knees,
126 ankles, second metatarsophalangeal (MTP) joints and the tips of the middle finger and
127 running shoe. Six video fields of the calibration structure were digitised in each camera view
128 to provide 11 DLT parameters (Abdel-Aziz & Karara, 1971). The raw 3D coordinates and the
129 force data were exported to a custom written Matlab script (v7.9.0, The MathWorks, USA)
130 for further processing. Position data were filtered with a low-pass, 2nd order, zero lag,
131 recursive Butterworth filter (Winter, 2009) with a cut-off frequency of 20 Hz. Force data
132 were filtered with a 150 Hz cut-off frequency, chosen based on previous sprint research under
133 similar testing conditions (Bezodis et al., 2014).

134

135 A 16-segment kinematic model of the human body was created. A standard 14-segment body
136 model, with inertia data from de Leva (1996), had the feet additionally split into rearfeet and
137 forefeet based on the average ratio of the male data obtained for Bezodis et al. (2012). The
138 mass of a typical spiked sprinting shoe (0.2 kg; Hunter et al., 2004) was added to the mass of
139 each foot with 85% and 15% added to the rearfeet and forefeet, respectively (Churchill et al.
140 2015). The ratios of the total mass for all segment masses were, thus, adjusted accordingly.

141

142 Gait events (touchdown and take off) were determined using a combination of force plate and
143 kinematic data. Touchdown and take-off on the force plate were defined using a two standard
144 deviation threshold of the mean zero-load vertical force. An alternative first touchdown event
145 was also determined from the peak vertical acceleration of the touchdown MTP point
146 (Bezodis et al., 2007) and used only for the purpose of calculating step time. Second

147 touchdown, which occurred off the force plate, was identified solely from this peak vertical
148 acceleration of the touchdown MTP.

149

150 *Calculation of variables*

151 All variables were measured separately for the left and right steps. A number of ground
152 reaction force variables were calculated and expressed relative to body weight (BW).
153 Impulses were calculated in absolute terms and also expressed relative to body mass.
154 Variables were selected based on force variables that have been shown to be important for
155 performance in the straight-line sprinting literature and in the limited bend sprinting
156 literature. These included peak values in horizontal, vertical and resultant directions, and the
157 mean values and impulses over ground contact in each direction. Force data were aligned
158 with the GCS for straight trials. During the bend trials, the horizontal forces in the GCS were
159 rotated relative to the direction of travel of the athlete using a finite difference method based
160 on the horizontal displacement of the Centre of Mass (CoM; Glaister et al., 2007).

161

162 Additionally, performance descriptors were selected based on those that have been shown to
163 be affected by sprinting on the bend (Churchill et al., 2015). Full details of the methods of
164 calculation of race velocity (the athletes' performance with respect to the official race
165 distance), race step length (the length of the race distance covered by each step), step
166 frequency and turn of the CoM during ground contact (the change in trajectory of the CoM
167 during contact to follow the curved path in the bend trials) can be found in Churchill et al.
168 (2015). In the present study, ground contact time was calculated as the time from touchdown
169 to take off, as identified using force plate data. Flight time was calculated as step time (based
170 on MTP acceleration data) minus ground contact time.

171

172 *Statistical analysis*

173 Paired samples t-tests were used to identify significant differences between left and right
174 steps for variables within the straight and bend conditions separately, and between the
175 straight and bend for the left and right steps separately. Based on Perneger (1998) and
176 additionally in order to limit the risk of a type II error, no adjustment was made to the alpha
177 level ($P < 0.05$). All statistical analyses were performed using IBM SPSS Statistics software
178 (v19.0, SPSS Inc., USA). Cohen's d effect sizes (Cohen, 1988) are provided in the results
179 section as additional contextualisation of the meaning of the results. Magnitudes less than or
180 equal to 0.20 represent a small difference, d greater than 0.20 but less than 0.80 a moderate
181 difference and d greater than or equal to 0.80 a large difference, between the two means.

182

183 **Results**

184 Mean peak resultant force during the left step was lower on the bend (3.61 ± 0.45 BW) than
185 the straight (3.82 ± 0.53 BW; $P = 0.044$, $d = 0.45$, Table 1). For the right step, however, mean
186 peak resultant force was greater on the bend (4.19 ± 1.29 BW) than the straight ($3.66 \pm$
187 0.29 BW; $P = 0.248$, $d = 0.57$, Table 1), although this result was markedly influenced by one
188 athlete producing a peak resultant force of 7.02 BW during the right step on the bend,
189 compared with 4.11 BW for the right step on the straight.

190

191 ***Table 1 near here***

192

193 Typical ground reaction force-time curves for the left and right steps on the bend and straight
194 are provided in Fig. 2. There was a 19% increase in braking impulse ($P = 0.012$, $d = 0.72$)
195 and the duration of braking (13% increase, $P = 0.003$, $d = 1.25$) for the left step on the bend
196 when compared with the left step on the straight (Table 2). Additionally, there was greater

197 braking impulse (33% increase, $P = 0.001$, $d = 1.34$) and duration of braking (30% increase,
198 $P < 0.0005$, $d = 2.84$) for the left compared with the right step on the bend. Mean peak inward
199 force and net inward impulse were higher during the left step than the right step on the bend
200 ($P = 0.018$, $d = 0.85$ and $P = 0.001$, $d = 2.46$, respectively, Table 3).

201

202 ***Fig. 2 near here***

203 ***Tables 2 and 3 near here***

204

205 Mean race velocity was 2.3% lower on the bend compared with the straight for both the left
206 step ($P = 0.012$, $d = 0.48$) and right step ($P = 0.001$, $d = 0.47$; Table 4). The mean right race
207 step length reduced from 2.12 ± 0.08 m on the straight to 2.02 ± 0.07 m on the bend
208 ($P = 0.030$, $d = 1.31$). This was accompanied by a slight increase in mean right step
209 frequency from 4.49 ± 0.22 Hz on the straight to 4.59 ± 0.23 Hz on the bend ($P = 0.225$,
210 $d = 0.47$). There were non-significant reductions (0.03 m) in left race step length ($P = 0.148$,
211 $d = 0.67$) and left step frequency (0.02 Hz decrease, $P = 0.404$, $d = 0.13$) from straight to
212 bend. A slight decrease in left step frequency and the increase in right step frequency on the
213 bend did, however, result in a significant difference between left and right steps on the bend
214 for this variable (right step frequency 0.15 Hz higher, $P = 0.024$, $d = 0.67$, Table 4), which
215 was not seen on the straight. Additionally, there was more turning (change of CoM trajectory)
216 achieved during the left step ($4.2 \pm 0.9^\circ$) than the right step ($2.6 \pm 0.7^\circ$) on the bend
217 ($P = 0.025$, $d = 1.99$, Table 4).

218

219 ***Table 4 near here***

220

221

222 **Discussion**

223 To the authors' knowledge this is the first full study to empirically investigate force
224 production in maximal effort sprinting on a radius and surface typical of outdoor athletic
225 competition. We investigated both whether the constant limb force hypothesis can be applied
226 to bend sprinting and how force production on the bend influences performance. Firstly, we
227 found that the constant limb force hypothesis is not fully valid in bend sprinting. Secondly,
228 there are clear disparities in force production and function between left and right legs, which
229 affect bend sprinting performance differently.

230

231 A reduction in left step peak vertical (9.8%) and resultant forces (5.7%) on the bend
232 compared with the straight confirms our study's first hypothesis, at least for the left step, that
233 lower vertical and resultant forces would be generated on the bend than on the straight. The
234 0.21 BW reduction in peak resultant force production in the present study for the left step on
235 the bend compared with the straight runs counter to Usherwood and Wilson's (2006) use of
236 the constant limb force assumption which suggested that athletes will generate a maximum
237 resultant force on the bend equal to that generated on the straight. Our finding, however,
238 concurs with the ground reaction force results of Chang and Kram (2007).

239

240 The bend did not appear to compromise vertical or resultant force production during the right
241 step (Table 1), thus the study's first hypothesis is rejected for the right step. In fact, peak
242 resultant force increased from 3.66 ± 0.29 BW on the straight to 4.19 ± 1.29 BW on the bend
243 for the right step (Table 1). This increase was, however, influenced by an exceptionally large
244 (more than seven times body weight) peak resultant force produced during the right step on
245 the bend by one athlete. These very large forces produced by this one athlete seems to have
246 been due to an individualised technique, as the athlete produced higher forces than any other

247 athlete in each of the conditions, even once normalised to body weight. This athlete was
248 running at the second highest velocity within that condition (9.66 m/s) and the ground contact
249 time for that step was the shortest at 0.097 s. When that athlete's result for peak resultant
250 force during the right step was removed, the group mean was 3.58 ± 0.23 BW on the straight
251 and 3.72 ± 0.37 BW on the bend. Although this was not statistically significant, the 14%
252 increase in right step peak resultant force on the bend compared with the straight, and
253 considering the substantial increase in force on the bend for some athletes, these results
254 demonstrate that the constant limb force hypothesis may not be valid for the right leg either.
255 Usherwood and Wilson (2006) were able to use their mathematical model effectively to
256 match indoor competition results based on the outdoor sprinting speeds. However, it is clear
257 the constant limb force hypothesis is not a valid assumption for humans sprinting maximally
258 on an outdoor athletics track, especially when specific information about force production is
259 required.

260

261 Naturally, the horizontal (anteroposterior) force production is also very important in
262 sprinting. As this study was conducted at the perceived maximum velocity phase, the net
263 anteroposterior impulse by default is very close to zero (just enough positive to counteract the
264 air resistance of the sprinter). Thus, we could not expect large differences in anteroposterior
265 forces between the conditions. However, there was a statistically significant difference in
266 anteroposterior propulsive impulse between straight and bend for the right step. This was
267 mainly due to one athlete as explained above. Gaudet (2014), using a mathematical model
268 containing several assumptions, speculated that during Berlin 2009 World Championships,
269 Usain Bolt applied 97.3% of the horizontal forces in the curve of the 200 m final in
270 comparison with his 100 m final in the same championships. In the current study, the left step
271 peak anteroposterior propulsive force on the bend was 93.0% of that on the straight. The

272 respective value for the right step was 106.3%. However, as our forces are actual measured
273 forces during a step and Gaudet's (2014) value is an estimation over a longer period of race,
274 we need to be careful of drawing any meaningful comparisons from the values.

275

276 Kinematic analysis of maximal (Churchill et al., 2015) and submaximal (Alt et al., 2015)
277 effort bend sprinting has shown that inward lean during bend sprinting results in greater
278 adduction of the left hip during the ground contact phase of bend sprinting compared with
279 straight-line sprinting. On the other hand, Churchill et al. (2015) reported that the right hip
280 abduction/adduction angle at touchdown was not significantly affected by the bend and that
281 peak adduction was less on the bend compared with the straight. The inward lean and
282 adduction/abduction angles could also influence why there were statistically significant
283 differences in horizontal braking impulses between left and right step on the bend (left step
284 braking larger) and between the straight and bend conditions for the left leg (bend condition
285 larger). It seems that due to inward lean, left leg has 'less room' (in relation to CoM) to
286 produce the pull-back action in the air and consequently makes contact earlier producing
287 larger and longer braking phases.

288

289 Some of the muscles that are involved in hip and knee flexion or extension are also involved
290 in controlling hip abduction or adduction (Palastanga et al., 2006). Thus, it is possible that
291 alterations to joint positions in the frontal plane may have an impact on those muscles' ability
292 to generate forces in the sagittal plane. Indeed, it has been suggested that the ability to sustain
293 forces in the frontal plane, whilst generating force in the sagittal plane, may be the limiting
294 factor to bend running performance (Chang & Kram, 2007). Measurement of 3D joint
295 moments whilst bend sprinting at track specific radii is lacking in the literature and is a
296 potential area for further investigation in order to establish whether frontal plane joint

297 moments are, in fact, limiting factors to bend running performance. These measures may also
298 explain the reduced vertical and resultant ground reaction forces observed for the left step and
299 why the right step force production appeared to be less affected in the present study.

300

301 In addition to the above, the position of the foot during the push off may have influenced the
302 force generation during the left and right steps on the bend. Although not directly measured
303 in the present study, Bojsen-Møller (1979) described the foot as being capable of using two
304 alternative axes for push off: the transverse and oblique axes. The transverse axis runs
305 through the first and second metatarsal heads, whereas the oblique axis runs through the
306 second to the fifth metatarsal heads (Bojsen-Møller, 1979). The use of these two axes affects
307 the congruency of the calcaneocuboid joint and the effectiveness of the windlass mechanism
308 of the plantar aponeurosis, which in turn affects the stability of the foot and so its
309 effectiveness for propulsion is likely superior when push off is about the transverse axis
310 rather than the oblique axis (Bojsen-Møller, 1979). It is probable that inward lean of the
311 athletes during bend running means that in the ground phase, the left foot contact is more
312 lateral and the right foot contact is more medial. This would mean the left foot would be more
313 likely to employ the oblique axis during the push off phase so may account for the reduction
314 in vertical force production during the left step on the bend compared with the straight. It
315 may also explain the significantly greater inward impulse generated on the left step compared
316 with the right step on the bend. In contrast, the right foot would be more likely to employ the
317 transverse axis, which may have contributed to maintenance of vertical and anteroposterior
318 propulsive force generation, but may not be conducive for inward force generation.

319

320 The present results for the left step do provide partial support for Usherwood and Wilson's
321 (2006) mathematical model, as a significant 10 ms increase in ground contact time was

322 observed for the left step on the bend compared with the straight (Table 4). Usherwood and
323 Wilson (2006) suggested, based on the research of Weyand et al. (2000), that the maximum
324 force an athlete is able to produce is already achieved during straight-line sprinting. They
325 postulated that ground contact time and the proportion of stride time spent in ground contact
326 during bend running would be increased in order to generate the centripetal force required to
327 follow the curved path. They suggested that swing time would remain constant and, therefore,
328 step frequency would decrease. The increased left step ground contact time in the present
329 study is in line with previously reported increases of 11 ms in left step ground contact time
330 during maximal effort bend sprinting (Churchill et al., 2015). Alt et al. (2015) revealed a
331 much smaller increase in contact time of the left step from straight to bend sprinting (2.6 ms).
332 Right step ground contact time decreased, although not significantly, on the bend compared
333 with the straight, again counter to the assumptions of Usherwood and Wilson (2006). The
334 reduction was less than in Alt et al. (2015) who found right ground contact time reduced
335 significantly on the bend compared with the straight. The observed differences between the
336 studies may be due to the fact that Alt et al. (2015) analysed matching velocities in two
337 conditions rather than maximal effort trials, allowing their athletes to have a relatively longer
338 contact time on the straight. The increased ground contact time in the current study enabled
339 maintenance of vertical impulse (only a 0.7 Ns reduction) for the left step on the bend
340 compared with the straight in the presence of significantly reduced mean vertical forces (0.11
341 BW). For the right step, vertical impulse results were similar between conditions, yet there
342 was a significant decrease in right step flight time (by 0.012 s), which had the effect of
343 significantly reducing right race step length (by 0.010 m). A reduction in right step length on
344 the bend compared with the straight has previously been shown in both the acceleration phase
345 (Stoner & Ben-Sira, 1979) and the maximum speed phase of bend sprinting (Churchill et al.,
346 2015).

347

348 The net inward impulse was significantly greater (61.2%) during the left step than the right
349 on the bend, resulting in 1.6° more turning of the CoM being achieved during the left than
350 right ground contact (Table 4). This greater inward impulse was produced via a combination
351 of both an increased contact time and a higher mean inward force (impulse divided by contact
352 time) being generated for the left step than the right step. This finding supports our second
353 hypothesis and suggests that there are functional differences between the left and right steps
354 in terms of force generation during bend sprinting. This finding is in line with our previous
355 kinematics study on a different participant group which also showed more turning was
356 achieved during the left step than the right (Churchill et al., 2015). Furthermore, the present
357 results contradict previous research that found the outer (right) leg generated greater peak
358 inward forces than the inside leg during maximal effort sprinting on radii of up to 6 m (Chang
359 & Kram, 2007) and during running (~5 m/s) on a curved path of 5 m radius on turf (Smith et
360 al., 2006). The tightness of the radii may account for the differences between those studies
361 (Chang & Kram, 2007; Smith et al., 2006) and the present study. Thus, the turning method
362 employed by sprinters running at maximal effort in athletic events appears to be different to
363 that of cutting actions, or of turning on very small radii. While the amount of turning of the
364 CoM is the consequence of the net impulse, there are various internal/external rotations
365 within joints and segments in bend sprinting. Regarding these rotational elements, Alt et al.
366 (2015) provided further insight into the functional differences between the legs. For example,
367 their results showed that the peak external rotation of the right ankle was three times more
368 than in the left ankle, although the overall external rotation from initial contact to peak
369 external rotation was similar in both ankles.

370

371 Mean peak inward forces during bend trials were over two-fold higher than the observed
372 mediolateral forces during straight trials (Table 3). These values were even larger than the
373 mean peak anteroposterior propulsive forces observed and may have potential implications
374 for strength training of athletes. Coupled with differences in frontal plane kinematics on the
375 bend compared with the straight, including leaning into the bend and hip abduction/adduction
376 angles (Alt et al., 2015; Churchill et al., 2015) and likely changes in frontal plane joint
377 moments on the bend when compared with the straight (Chang & Kram, 2007), these aspects
378 should be a consideration in both strength and technique training for athletes. For example,
379 athletes should ensure that they undertake some maximum-speed training on the bend in
380 order that the high forces whilst leaning are not only experienced during a competition
381 setting. This means that when the focus of the training is the bend, the starting positions
382 should, at times, be such that a substantial proportion of the maximum-speed phase occurs on
383 the bend. Additionally, the use of ropes or harnesses may allow athletes to be supported in a
384 leaning position during strength training and/or plyometric training. Moreover, the demands
385 of the left and right steps on the bend appear to be functionally different, but care should be
386 taken to avoid introducing asymmetries, such as strength imbalances, that might be
387 detrimental to the straight-line portion of the race.

388

389 The straight line velocities, step lengths and step frequencies achieved in the present study
390 (Table 4) were similar to those reported in previous studies of the maximal phase of straight
391 line sprinting in athletes of similar calibre (Bezodis et al., 2008; Churchill et al., 2015; Mero
392 & Komi, 1986). Furthermore, the athletes in the present study were able to achieve vertical
393 and anteroposterior ground reaction forces on the straight which were similar to previously
394 reported values. For example, Korhonen et al. (2010) reported peak vertical, braking and
395 anteroposterior propulsive ground reaction forces of 3.35 BW, 1.43 BW and 0.74 BW,

396 respectively, for athletes sprinting on the straight at a similar velocity (9.5 m/s). These
397 findings confirm that the athletes in our study were typical competitive athletes performing
398 normally. However, a limitation of the present study is that the number of trials was limited
399 to a maximum of six per athlete in total, as the quality of runs may not be maintained at
400 maximal effort beyond that, highlighting challenges when investigating competitive sprinters
401 in ecologically valid situations. This meant that only one successful foot strike on the force
402 plate was achieved for each foot under each condition for each athlete. Force data from
403 multiple steps have been collected in sprinting (e.g. Belli et al., 2002; Korhonen et al., 2010;
404 Mero & Komi, 1986; Morin et al., 2011, 2012). However, these have been carried out either
405 on instrumented treadmills (Morin et al., 2011, 2012), which is not applicable to track bend
406 sprinting, or on long multiple force plates (Belli et al., 2002; Korhonen et al., 2010; Mero &
407 Komi, 1986) that are not readily available. Data collection on separate occasions would have
408 facilitated multiple trials per foot per condition, but this would have increased variation due
409 to data being collected on different days and would likely have increased participant drop-
410 out. It is acknowledged that there was a relatively limited sample size in this study. However,
411 this was due to the requirement to have high calibre athletes who were experienced in bend
412 sprinting and competing regularly so that any differences found could be confidently
413 attributed to the running condition rather than the novelty of the task. Despite being a limited
414 sample, statistically significant results were found, and differences in force production
415 between the bend and straight were still identified.

416

417 **Perspectives**

418 We believe this is the first investigation of the kinetics of maximal effort bend sprinting on a
419 surface and radius typical of an outdoor athletics track. Overall force production reduced on
420 the left step on the bend resulting in lower velocity, contrary to the assumptions of

421 Usherwood and Wilson's (2006) mathematical model. The decrease in velocity was due to
422 decreased step length and frequency similar to Alt et al. (2015) and Churchill et al. (2015).
423 However, the left step contributed more than the right step to the generation of inward
424 impulses and turning, contradicting studies of small radii (Chang & Kram, 2007; Smith et al.,
425 2006). Resultant force increased during the right foot contact, although step velocity reduced
426 due to shorter step length. This was possibly due to difficulties in repositioning the left leg for
427 the subsequent contact leading to an abbreviated step. Force requirements of bend sprinting
428 were considerably different to those of straight-line sprinting with asymmetries between left
429 and right steps observed on the bend. Therefore, bend specific strength and technique training
430 performed at high velocity may improve athletes' ability to meet the requirements of bend
431 sprinting, thus improving performance during this portion of a race.

432

433 **Acknowledgement:**

434 This research was part funded by UK Athletics Ltd.

435 **References**

436 Abdel-Aziz YI, Karara HM. Direct linear transformation from comparator coordinates into
437 object space coordinates in close range photogrammetry. American Society of
438 Photogrammetry Symposium on Close-Range Photogrammetry, Falls Church, VA:
439 American Society of Photogrammetry; 1971: 1-18.

440

441 Alt T, Heinrich K, Funken J, Potthast W. Lowerextremity kinematics of athletics curve
442 sprinting. J Sports Sci 2015; 33: 552-560.

443

444 Belli A, Kyröläinen H, Komi PLV. Moment and power of lower limb joints in running. Int J
445 Sports Med: 2002; 23: 136-141.

446

447 Bezodis I, Thomson A, Gittoes M, Kerwin D. Identification of instants of touchdown and
448 take-off in sprint running using an automatic motion analysis system. In: Proceedings
449 of the XXV International Symposium on Biomechanics in Sports. Ouro Preto, Brazil:
450 International Society of Biomechanics in Sports, 2007: 501-504.

451

452 Bezodis IN, Kerwin DG, Salo, AIT. Lower-limb mechanics during the support phase of
453 maximum-velocity sprint running. Med Sci Sports Exerc 2008; 40: 707-715.

454

455 Bezodis NE, Salo AIT, Trewartha G. Modeling the Stance Leg in Two-Dimensional
456 Analyses of Sprinting: Inclusion of the MTP Joint Affects Joint Kinetics. J Appl
457 Biomech 2012; 28: 222-227

458

459 Bezodis, NE, Salo, AIT, Trewartha G. Lower limb joint kinetics during the first stance phase
460 in athletics sprinting: three elite athlete case studies. *J Sports Sci* 2014; 32: 738-746.
461

462 Bojsen-Møller F. Calcaneocuboid joint and stability of the longitudinal arch of the foot at
463 high and low gear push off. *J. Anat* 1979; 129: 165-176.
464

465 Chang YH, Kram R. Limitations to maximum running speed on flat curves. *J Exp Biol* 2007:
466 210: 9719-82.
467

468 Churchill SM, Salo AIT, Trewartha G. The effect of the bend on technique and performance
469 during maximal effort sprinting. *Sport Biomech* 2015; 14: 106-121.
470

471 Cohen J. *Statistical Power Analysis for the Behavioral Sciences*. Hillsdale, NJ: Lawrence
472 Erlbaum Associates, 1988.
473

474 de Leva P. Adjustments to Zatsiorsky-Seluyanov's segment inertia parameters. *J Biomech*
475 1996; 29: 1223-1230.
476

477 Gaudet S. A physical model of sprinting. *J Biomech* 2014; 47: 2933-2940.
478

479 Glaister BC, Orendurff MS, Schoen JA, Klute GK. Rotating horizontal ground reaction
480 forces to the body path of progression. *J Biomech* 2007; 40: 3527-3532.
481

482 Greene PR. *Running on flat turns: Experiments, theory and applications*. *J Biomech Eng-T*
483 *ASME* 1985; 107: 96-103.

484
485
486
487
488
489
490
491
492
493
494
495
496
497
498
499
500
501
502
503
504
505
506
507
508

Hamill J, Murphy M, Sussman D. The effects of track turns on lower extremity function. *Int J Sport Biomech* 1987; 3: 276-286.

Hunter JP, Marshall RN, McNair PJ. Interaction of step length and step rate during sprint running. *Med Sci Sports Exerc* 2004; 36: 261-271.

Kearney JT. Sport performance enhancement: design and analysis of research. *Med Sci Sports Exerc* 1999;31: 755-756.

Korhonen MT, Suominen H, Viitasalo JT, Liikavainio T, Alen M, Mero AA. Variability and symmetry of force platform variables in maximum-speed running in young and older athletes. *J Appl Biomech* 2010; 26: 357-366.

Mero A, Komi PV. Force-, EMG-, and elastic-velocity relationships at submaximal, maximal and supramaximal running speeds in sprinters. *Eur J Appl Physiol* 1986; 55: 553-561.

Morin J-B, Edouard P, Samozino P. Technical ability of force application as a determinant factor of sprint performance. *Med Sci Sports Exerc* 2011;43: 1680-1688.

Morin JB, Bourdin M, Edouard P, Peyrot N, Samozino P, Lacour JR. Mechanical determinants of 100-m sprint running performance. *Eur J Appl Physiol* 2012;112: 3921-3930.

509 Palastanga N, Field D, Soames R. Anatomy and human movement: Structure and function.
510 Philadelphia: Elsevier, 2006.
511

512 Perneger TV. What's wrong with Bonferroni adjustments. *Brit Med J* 1998; 316: 1236-1238
513

514 Smith G. Padding point extrapolation techniques for the Butterworth digital-filter. *J Biomech*
515 1989; 22: 967-971.
516

517 Smith N, Dyson R, Hale T, Janaway L. Contributions of the inside and outside leg to
518 maintenance of curvilinear motion on a natural turf surface. *Gait Posture* 2006; 24:
519 453-458.
520

521 Stoner LJ, Ben-Sira D. Sprinting on the curve. In: Terauds J, Dales GG, editors. *Science in*
522 *Athletics*. Del Mar, CA: Academic Publishers, 1979: 167-173.
523

524 Usherwood JR, Wilson AM. No force limit on greyhound sprint speed. *Nature* 2005; 438:
525 753-754.
526

527 Usherwood JR, Wilson AM. Accounting for elite indoor 200 m sprint results. *Biol Letters*
528 2006; 2: 47-50.
529

530 Weyand PG, Sternlight DB, Bellizzi MJ, Wright S. Faster top running speeds are achieved
531 with greater ground forces not more rapid leg movements. *J Appl Physiol* 2000; 89:
532 1991-1999.
533

534 Winter DA. Biomechanics and motor control of human movement. Hoboken, New Jersey:
535 John Wiley & Sons, Inc., 2009.

Table 1. Left and right step group mean values (\pm SD) and significant differences for vertical and resultant force variables on the straight and bend.

| | Straight | | Bend | | Significant differences | | | |
|---------------------------------|-----------------|-----------------|-----------------|-----------------|-------------------------|---------------------|------------------------|-------------------------|
| | Left | Right | Left | Right | Left vs. right Straight | Left vs. right Bend | Straight vs. bend Left | Straight vs. bend Right |
| Peak vertical force (BW) | 3.80 \pm 0.52 | 3.64 \pm 0.29 | 3.43 \pm 0.41 | 4.13 \pm 1.27 | | | # | |
| Mean vertical force (BW) | 2.13 \pm 0.25 | 2.05 \pm 0.14 | 2.02 \pm 0.20 | 2.09 \pm 0.20 | | | # | |
| Vertical impulse (Ns) | 82.0 \pm 18.2 | 76.9 \pm 13.0 | 81.3 \pm 17.4 | 78.4 \pm 18.0 | | | | |
| Relative vertical impulse (m/s) | 1.16 \pm 0.21 | 1.09 \pm 0.07 | 1.15 \pm 0.20 | 1.11 \pm 0.18 | | | | |
| Peak resultant force (BW) | 3.82 \pm 0.53 | 3.66 \pm 0.29 | 3.61 \pm 0.45 | 4.19 \pm 1.29 | | | * | |
| Mean resultant force (BW) | 2.23 \pm 0.26 | 2.14 \pm 0.15 | 2.18 \pm 0.21 | 2.22 \pm 0.20 | | | | |

* significant at $P < 0.05$; # significant at $P < 0.01$

Table 2. Left and right step group mean values (\pm SD) and significant differences for anteroposterior force variables on the straight and bend.

| | Straight | | Bend | | Significant differences | | | |
|---|-------------------|-------------------|-------------------|-------------------|-------------------------|---------------------|------------------------|-------------------------|
| | Left | Right | Left | Right | Left vs. right Straight | Left vs. right Bend | Straight vs. bend Left | Straight vs. bend Right |
| Peak braking force (BW) | 1.43 \pm 0.39 | 1.31 \pm 0.26 | 1.41 \pm 0.34 | 1.31 \pm 0.22 | | | | |
| Braking impulse (Ns) | 14.0 \pm 3.7 | 13.2 \pm 3.8 | 16.6 \pm 3.5 | 12.4 \pm 2.8 | | # | * | |
| Relative braking impulse (m/s) | 0.20 \pm 0.04 | 0.18 \pm 0.04 | 0.23 \pm 0.02 | 0.17 \pm 0.02 | | § | * | |
| Duration of braking (s) | 0.046 \pm 0.006 | 0.044 \pm 0.007 | 0.052 \pm 0.004 | 0.040 \pm 0.004 | | § | # | |
| Peak anteroposterior propulsive force (BW) | 0.81 \pm 0.09 | 0.73 \pm 0.07 | 0.76 \pm 0.09 | 0.77 \pm 0.07 | * | | | |
| Anteroposterior propulsive impulse (Ns) | 18.3 \pm 3.7 | 16.8 \pm 3.7 | 19.1 \pm 2.8 | 18.7 \pm 3.9 | | | | * |
| Relative anteroposterior propulsive impulse (m/s) | 0.26 \pm 0.02 | 0.24 \pm 0.03 | 0.27 \pm 0.02 | 0.26 \pm 0.03 | | | | * |
| Duration of anteroposterior propulsion (s) | 0.061 \pm 0.004 | 0.064 \pm 0.006 | 0.064 \pm 0.003 | 0.064 \pm 0.005 | | | # | |

* significant at $P < 0.05$; # significant at $P < 0.01$; § significant at $P < 0.001$

Table 3. Left and right step group mean values (\pm SD) and significant differences for mediolateral force variables on the straight and bend.

| | Straight | | Bend | | Significant differences | | | |
|--|-----------------|-----------------|-----------------|-----------------|-------------------------|---------------------|------------------------|-------------------------|
| | Left | Right | Left | Right | Left vs. right Straight | Left vs. right Bend | Straight vs. bend Left | Straight vs. bend Right |
| Peak medial force (BW) | 0.41 \pm 0.11 | 0.41 \pm 0.11 | | | | | | |
| Peak lateral force (BW) | 0.22 \pm 0.14 | 0.25 \pm 0.06 | | | | | | |
| Net mediolateral impulse (Ns) ¹ | 3.2 \pm 5.0 | 5.3 \pm 2.1 | | | | | | |
| Relative net lateral impulse (m/s) | 0.05 \pm 0.08 | 0.08 \pm 0.03 | | | | | | |
| Peak inward force (BW) | | | 1.07 \pm 0.22 | 0.86 \pm 0.25 | | * | | |
| Net inward impulse (Ns) | | | 39.9 \pm 6.5 | 24.7 \pm 5.8 | | # | | |
| Relative net inward impulse (m/s) | | | 0.56 \pm 0.05 | 0.35 \pm 0.06 | | # | | |

¹ A positive value indicates a net lateral impulse (away from the midline of the body); * significant at $P < 0.05$; # significant at $P < 0.01$

Table 4. Left and right step group mean values (\pm SD) and significant differences for performance descriptors on the straight and bend.

| | Straight | | Bend | | Significant differences | | | |
|-------------------------|-------------------|-------------------|-------------------|-------------------|----------------------------|------------------------|---------------------------|----------------------------|
| | Left | Right | Left | Right | Left vs. right Straight | Left vs. right Bend | Straight vs. bend Left | Straight vs. bend Right |
| Race velocity (m/s) | 9.56 \pm 0.46 | 9.51 \pm 0.47 | 9.34 \pm 0.43 | 9.29 \pm 0.47 | | | * | # |
| Race step length (m) | 2.14 \pm 0.05 | 2.12 \pm 0.08 | 2.11 \pm 0.05 | 2.02 \pm 0.07 | | * | | * |
| Step frequency (Hz) | 4.46 \pm 0.23 | 4.49 \pm 0.22 | 4.44 \pm 0.25 | 4.59 \pm 0.23 | | * | | |
| Ground contact time (s) | 0.107 \pm 0.008 | 0.108 \pm 0.008 | 0.117 \pm 0.006 | 0.104 \pm 0.005 | | § | # | |
| Flight time (s) | 0.116 \pm 0.019 | 0.120 \pm 0.014 | 0.118 \pm 0.011 | 0.108 \pm 0.016 | | | | * |
| Turn of CoM (°) | | | 4.2 \pm 0.9 | 2.6 \pm 0.7 | | * | | |

* significant at $P < 0.05$; # significant at $P < 0.01$; § significant at $P < 0.001$

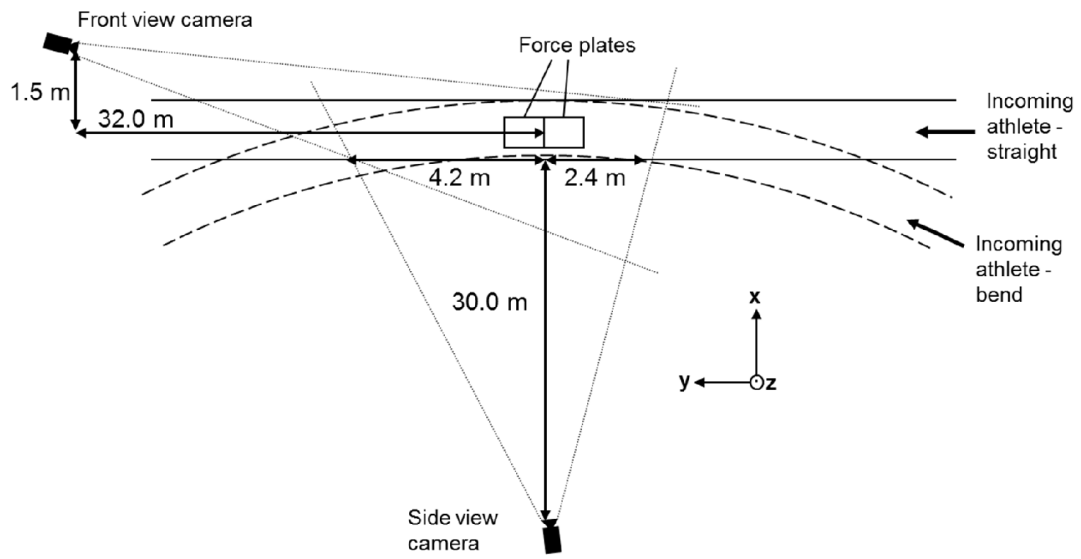
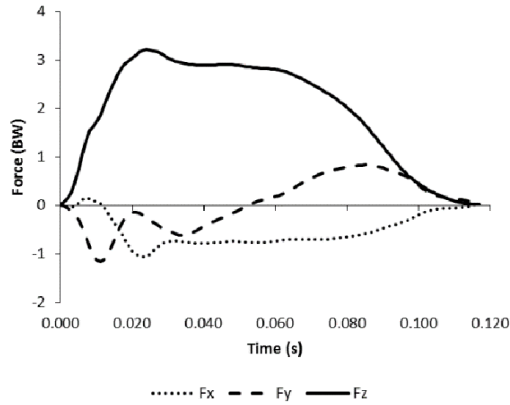
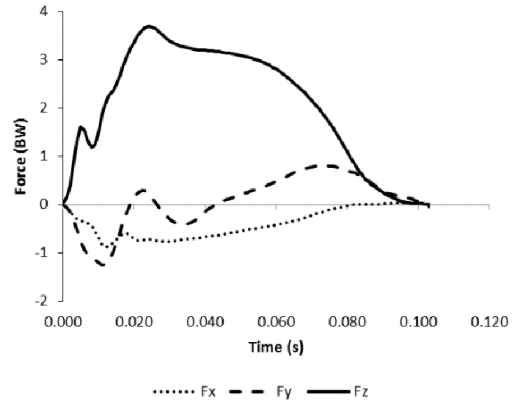

Fig 1. Camera set-up for bend and straight trials (not to scale).

(a) Bend – Left step



(b) Bend – Right step



(c) Straight – Left step

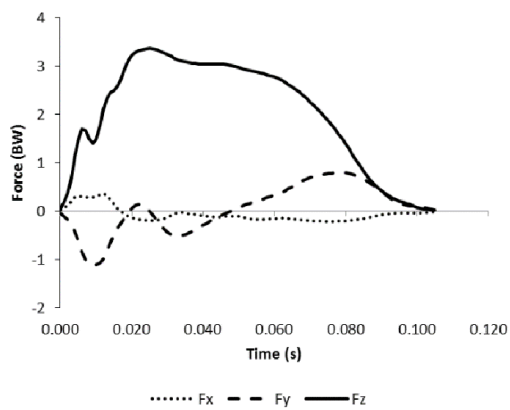

(d) Straight – Right step

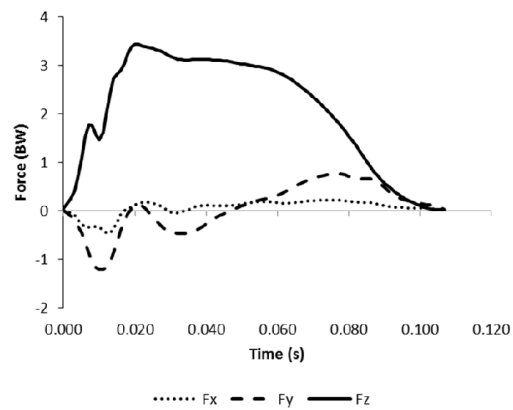

Fig 2. Ground reaction forces for one participant's left and right steps on the bend and straight. Negative Fx on the bend represents inward force; Negative and positive Fx for the left step on the straight represents lateral and medial force, respectively; Negative and positive Fx for the right step on the straight represents medial and lateral force, respectively. Negative and positive Fy represents braking and anteroposterior propulsive force, respectively. Positive Fz represents upwards vertical force.