



Citation for published version:

Pegg, E, Dodd, CAF, Murray, D & Pandit, H 2015, 'Conservative Tibial Resection and Vertical Cut Minimise Risk of Tibial Plateau Fracture after UKR', SIMULIA Community Conference, Berlin, Germany, 19/04/15 - 21/05/15.

Publication date:
2015

Document Version
Publisher's PDF, also known as Version of record

[Link to publication](#)

University of Bath

Alternative formats

If you require this document in an alternative format, please contact:
openaccess@bath.ac.uk

General rights

Copyright and moral rights for the publications made accessible in the public portal are retained by the authors and/or other copyright owners and it is a condition of accessing publications that users recognise and abide by the legal requirements associated with these rights.

Take down policy

If you believe that this document breaches copyright please contact us providing details, and we will remove access to the work immediately and investigate your claim.

Conservative Tibial Resection and Vertical Cut Minimise Risk of Tibial Plateau Fracture after UKR

E.C.Pegg¹, CAF Dodd¹, DW Murray¹, HG Pandit¹

¹ Nuffield Department of Orthopaedics, Rheumatology and Musculoskeletal Sciences, University of Oxford, UK



UNIVERSITY OF
OXFORD

Introduction

Tibial fracture is a known complication after unicompartmental knee replacement (UKR) [1]. The clinical consequences of tibial fracture can be severe. Unless the fracture occurs and propagates intraoperatively, further surgery is usually necessary and in severe cases revision to a stemmed total knee replacement may be required.

Our aim was to identify surgical factors that contribute to fracture. We examined the influence of tibial saw cuts on the risk of fracture after cementless UKR, to determine if changes in tibial preparation could minimise the risk of fracture.



Fig.1. The Oxford Unicompartmental Knee

Methodology

Twenty three tibial Sawbones from an instructional course were measured to identify the typical surgical cut positions and depths for unicompartmental knee replacement. Parameters measured are shown in figure 2. The distributions for each parameter were found and these were then used to create the finite element models.

Using the Monte Carlo method, a thousand finite element models were created using Abaqus software (version 6.12, Simulia, Providence, RI) each one with a different combination of surgical cuts. The process was automated using python scripting.

The risk of fracture (ROF) was quantified using the definition reported by Schileo *et al.* based upon the principal strain (ϵ) criterion, where:

$$ROF = \begin{cases} \epsilon/0.0073 & \text{if tensile} \\ \epsilon/0.0104 & \text{if compressive} \end{cases}$$

The models were based upon a study performed previously [2]; material properties of the bone were assigned using the Hounsfield units of the CT scan, the distal end of the tibia was fixed in all degrees of freedom and the loads applied were found from a musculoskeletal model based upon measurements from an instrumented knee prosthesis. A mesh size of 2.4 mm was used after performing a mesh convergence study.

A generalised linear regression model was performed to examine each parameter and how it influences the risk of fracture, using R (www.r-project.org).

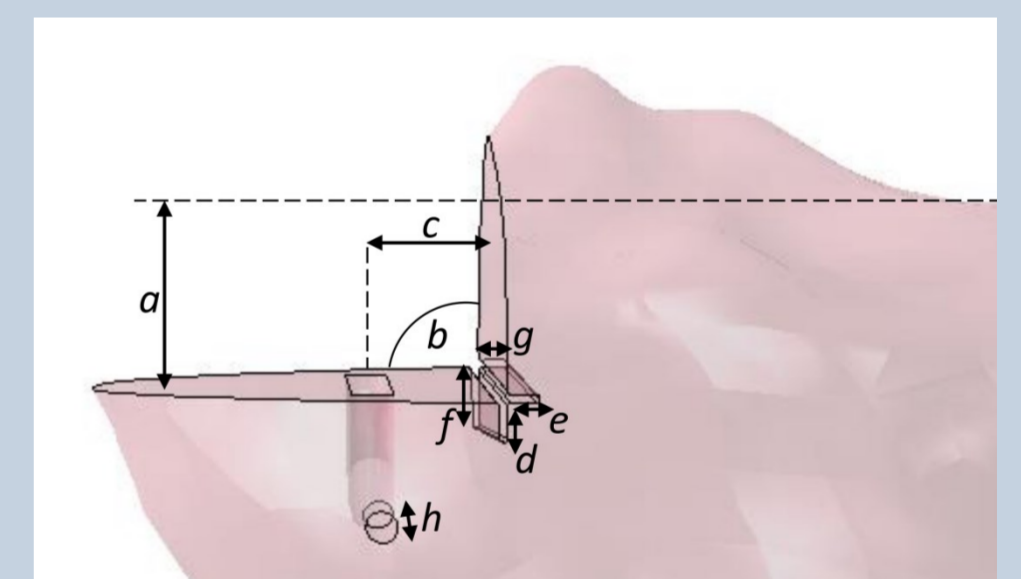

Fig.2. Measurements made on Sawbones from an instructional course for UKR

Results and Discussion

Some of the finite element models, particularly those with a deep posterior vertical cut, had a region at high risk of fracture which followed a line from the vertical cut to the cortex (Fig. 3) which is a typical path of fracture observed in clinically [1].

The generalised linear regression model found that the both the resection depth and the depth of the vertical cut posteriorly significantly increased the risk of fracture (Fig. 4. and Table 1).

Furthermore, the regression model showed that an excessively deep horizontal cut, both posteriorly and anteriorly, reduced the risk of fracture. Although significant, the positive influence of an excessive horizontal cut was not as great as the negative influence of an excessive vertical cut or resection depth.

The overall regression fit had a correlation coefficient of 0.77 indicating the parameters assessed accounted for the 77% of the variation.

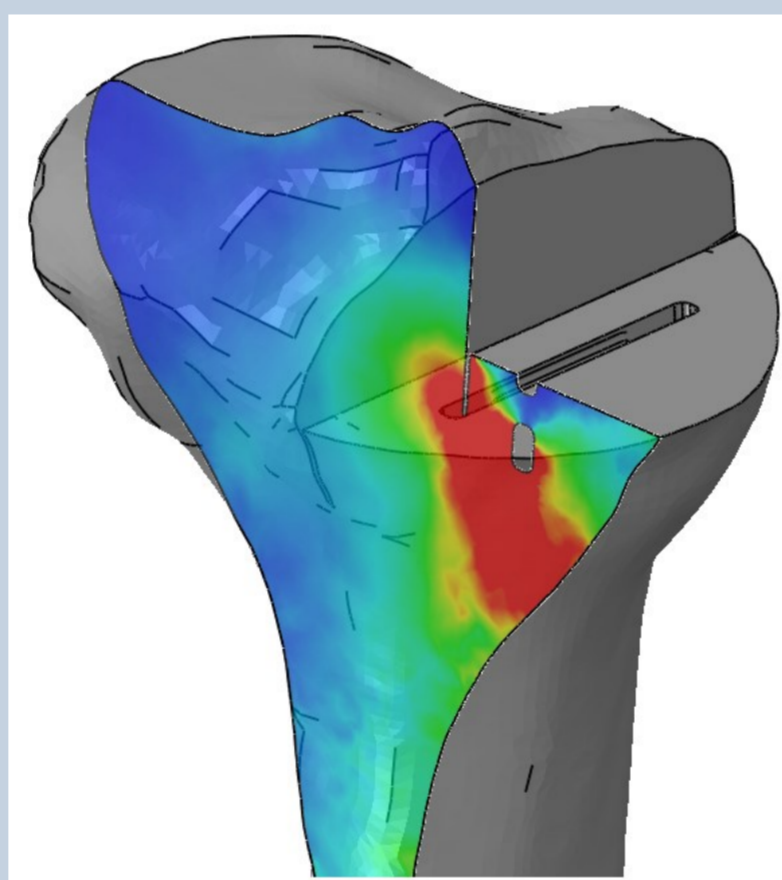

Fig.3. Risk of fracture after UKR for a deep posterior vertical cut. Red = high risk, blue = low risk

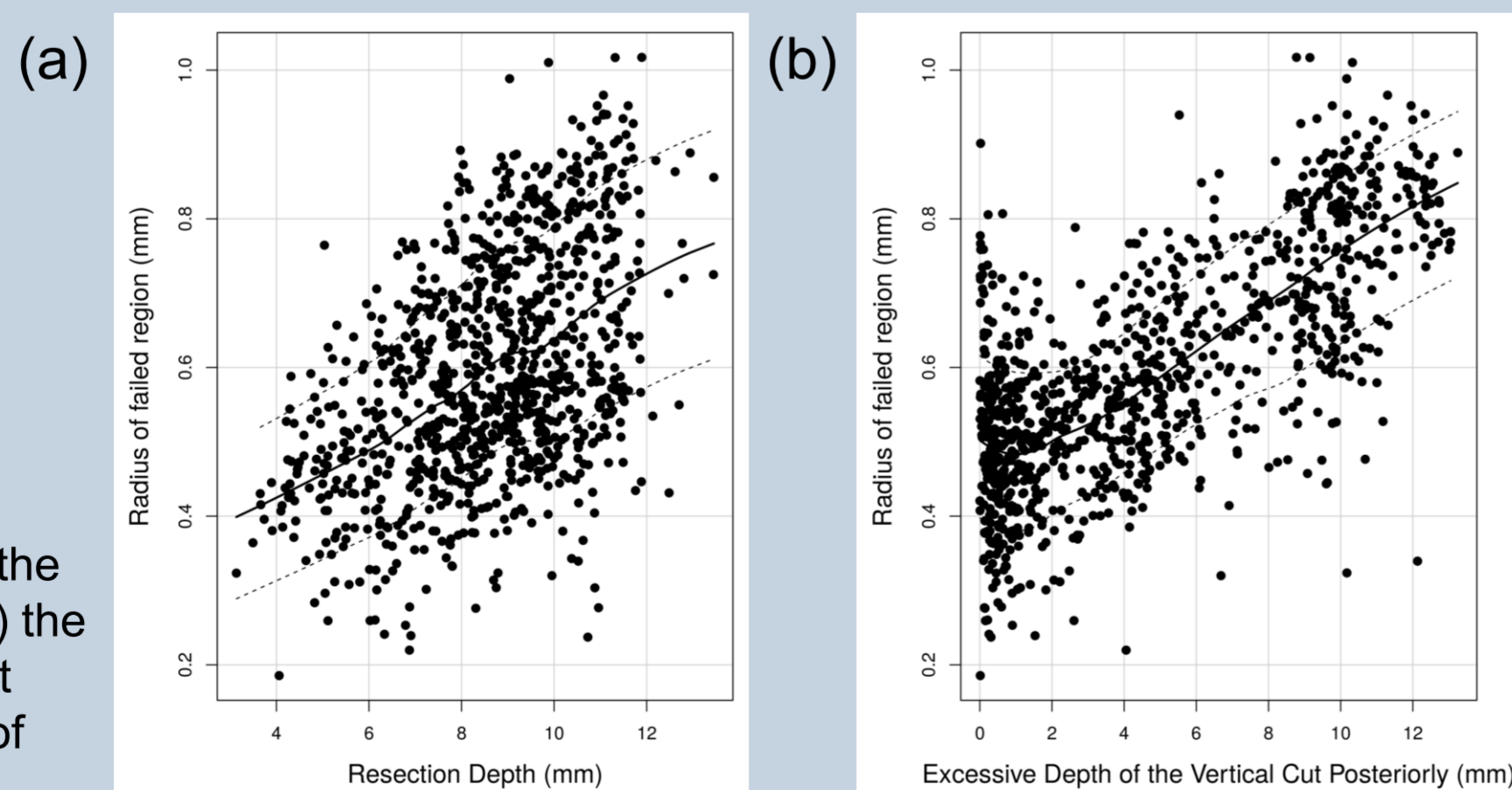

Fig. 4. Influence of (a) the resection depth and (b) the depth of the vertical cut posteriorly on the risk of fracture.

Parameter	Coefficient	Standard Error	Probability	Significance
a (resection depth, mm)	0.037	0.001	2.00e-16	***
d (vertical cut anterior, mm)	-0.003	0.002	0.144	
e (horizontal cut anterior, mm)	-0.011	0.003	2.03e-5	***
f (vertical cut posterior, mm)	0.027	0.001	2.00e-16	***
g (horizontal cut posterior, mm)	-0.017	0.001	2.00e-16	***
h (pin depth, mm)	-2.0e-4	3.5e-4	0.567	
Intercept	0.194	0.015	2.00e-16	***

Table 1. Result of the generalised linear regression model

Conclusions

The results of this study have highlighted the importance of careful surgical preparation of the tibial plateau prior to UKR implantation. This study suggests that the cause of fracture is multifactorial, and that to minimise the risk of fracture a surgeon should: (1) ensure that the vertical cut does not go too deep posteriorly, and (2) be conservative with resection of the tibia.

Instrumentation may play a role in achieving these goals. If the horizontal cut were to be made prior to the vertical cut, a shim could be inserted to stop the vertical cut from going too deep. This would increase the chance of the horizontal cut being extended further lateral underneath the tibial spines and present a deep vertical cut; both of which decrease the risk of fracture. Improvements could also be made to surgeon training and the risk could be better communicated.

1. HG Pandit, DW Murray, CAF Dodd, et al. *Medial tibial plateau fracture and the Oxford unicompartmental knee.* Orthopaedics 30 p28-31 (2007)

2. EC Pegg, J Walter, SJ Mellon, et al. *Evaluation of factors affecting tibial bone strain after unicompartmental knee replacement.* J Orthop Res 31 p821-8 (2013)