



*Citation for published version:*

Galindo, R & Ngwompo, R 2016, 'A Bond Graph Pseudo-Junction Structure for Non-Linear Non-conservative Systems', Paper presented at UKACC International Conference on Control, Belfast, UK United Kingdom, 31/08/16 - 2/09/16.

*Publication date:*  
2016

[Link to publication](#)

**University of Bath**

**Alternative formats**

If you require this document in an alternative format, please contact:  
[openaccess@bath.ac.uk](mailto:openaccess@bath.ac.uk)

**General rights**

Copyright and moral rights for the publications made accessible in the public portal are retained by the authors and/or other copyright owners and it is a condition of accessing publications that users recognise and abide by the legal requirements associated with these rights.

**Take down policy**

If you believe that this document breaches copyright please contact us providing details, and we will remove access to the work immediately and investigate your claim.

# A Bond Graph Pseudo-Junction Structure for Non-Linear Non-conservative Systems

R. Galindo<sup>1</sup>

Faculty of Electrical and Mechanical Engineering  
of the Autonomous University of Nuevo Leon, Mexico.  
E-mail: rgalindo@gama.fime.uanl.mx

R. F. Ngwompo<sup>2</sup>

Centre for Power Transmission and Motion Control  
Department of Mechanical Engineering  
University of Bath.  
E-mail: r.f.ngwompo@bath.ac.uk

**Abstract**—Bond graph (BG) models are widely used to display various fields of a physical system and their interconnection. In this paper, a BG pseudo-junction structure for non-linear and non-conservative systems is proposed. This BG pseudo-junction structure has an inner structure that satisfies energy conservation properties and a multiport-coupled dissipative field that determines the physical realisability of the system. Properties of the dissipative field like passivity are highlighted by the proposed BG pseudo-junction structure. The results are illustrated through examples.

**Keywords.**— Non-conservative; Non-linear; Pseudo-junction structure; Structural properties; Passivity; Bond graph

## 1. Introduction

State space and transfer function descriptions have been widely used to represent dynamic systems. These time domain and frequency domain models, respectively, are useful, compact and abstract descriptions with parameters and variables that may not have physical meanings. The work of [Gawthrop, 1995] designed controllers in the physical domain based on Bond Graph (BG) models (see [Karnopp and Rosenberg, 1975]). BG (see [Karnopp and Rosenberg, 1975]) usually models a physical system and the parameters and variables have physical meanings. The associated bonds have two associated variables whose product is power, however, it is not allowed in general to manipulate only one variable. An approach for the passification of mechatronic systems is proposed by [Li and Ngwompo, 2005], based on power scaling transformers and gyrators. However, the work of [Li and Ngwompo, 2005] does not cover the interconnection of subsystems.

The aim of the present work is to develop a new BG pseudo-junction structure description that is closer to the above abstract descriptions. A BG pseudo-junction structure is proposed in section 3 that includes an associated inner pseudo-junction structure that satisfies energy conservation properties and a multiport-coupled dissipative field that determines the physical realisability of the system. This

dissipative field and inner pseudo-junction structure highlights the energy properties like passivity. The proposed BG pseudo-junction structure can be seen as consisting of an inner and an outer structures and these are called pseudo because of the non conservation of power in the outer structure. As shown in Fig. 1 the proposed BG pseudo-junction structure allows to represent non-linear and non-conservative as well as conservative systems modelled by BG or by state space descriptions.

Active bonds are used to manipulate only one variable leading to non-conservation of energy, which can also be interpreted as power scaling [Li and Ngwompo, 2005]. This signal bond is widely used in control theory for the interconnection of sub-systems using internal modulated sources of energy that are modelled as power scaling transformers and gyrators in the work of [Li and Ngwompo, 2005]. These interconnected sub-systems can lead to an overall non-conservative system.

In Fig. 1, the BG pseudo-junction structures are not unique descriptions, so, for linear systems, state space descriptions obtained from given BG (see [Karnopp and Rosenberg, 1975]) do not recover in general the original BG using the work of [Gonzalez and Galindo, 2009].

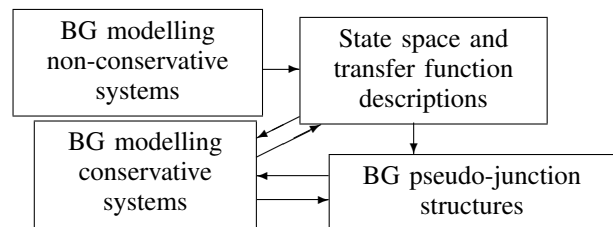

Figure 1. BG pseudo-junction descriptions

In section 2, a brief review of junction structure background and its structural properties, is given. The proposed BG pseudo-junction structure is presented in section 3. The results are illustrated by examples. Finally conclusions are given in the last section.

**Notation**  $\mathcal{I}_p$  is the identity matrix of dimension  $p \times p$ ; and  $\text{diag}\{a_1, a_2, \dots, a_n\}$  is a diagonal matrix of dimension  $n \times n$  whose elements are  $a_1, a_2, \dots, a_n$ .

1. This paper was developed under CONACyT project 00000000261574

2. Corresponding author

## 2. Background

Suppose that a predefined integral causality is assigned to a standard Bond Graph (BG) [Karnopp and Rosenberg, 1975]. In this BG, all the bonds can be classified as external bonds on the one hand, connecting the storage elements  $C$  and  $I$  in integral causality, the dissipative elements  $R$ , and the sources of effort and flow  $S_e$  and  $S_f$ , respectively, and as internal bonds on the other hand, connecting the elements of the junction structure  $S$ , as shown in Fig. 2. Junction structures are assemblage of 0- junctions and 1- junctions, transformers,  $TF$ , and gyrators,  $GY$ , which disable or enable the energy interchange which enforce the constraints among parts of dynamic systems. In Fig. 2,  $x(t) \in \mathbb{R}^{n \times 1}$  is the state vector associated with  $I$  and  $C$  elements in integral causality,  $z(t) = \phi(x(t)) \in \mathbb{R}^{n \times 1}$  is the co-energy vector composed of effort and flow variables,  $D_o(t) = \psi(D_i(t)) \in \mathbb{R}^{q \times 1}$  and  $D_i(t) \in \mathbb{R}^{q \times 1}$  are vectors which relate efforts and flows between the dissipation field  $R$  and  $S$ , and  $u(t) \in \mathbb{R}^{m \times 1}$  and  $y(t) \in \mathbb{R}^{p \times 1}$  are the system input and output, respectively.

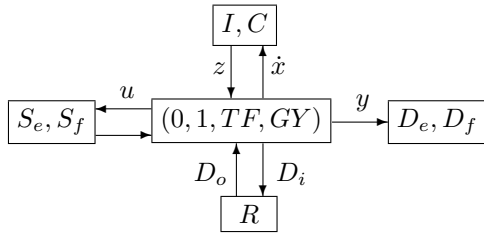

Figure 2. Junction structure

The relationships for the junction structure are given by:

$$\begin{bmatrix} \dot{x}(t) \\ D_i(t) \\ y(t) \end{bmatrix} = S \begin{bmatrix} z(t) \\ D_o(t) \\ u(t) \end{bmatrix} \quad (1)$$

where  $S$  has a block partition according to the dimensions of  $z(t)$ ,  $D_o(t)$  and  $u(t)$ .

Also, the junction structures are special type of fields that do not store or dissipate power, and their structural properties (see [Karnopp and Rosenberg, 1975], [Sueur and Dauphin-Tanguy, 1989] and [Lamb *et al.*, 1997]) are stated as follows,

- P1 .  $S_{11}$  and  $S_{22}$ , are skew-symmetric,
- P2 .  $S_{12} = -S_{21}^T$ ,
- P3 . When the elements of  $R$  are linearly independent, there are no direct causal paths between these elements and  $S_{22} = 0$ .

In the case of conservative systems a sufficient condition of inexistence of asymptotic stability is that there exist a linear combination between the rows of  $\begin{bmatrix} S_{11} & S_{12} \end{bmatrix}$ . Also, structural controllability and observability have been analysed in [Sueur and Dauphin-Tanguy, 1989].

The aim is to model a given non-linear and non-conservative system decomposing it into a part that is power

conserving and a multiport-coupled dissipative field that might be non-passive. This problem is tackled in the next section where the main results present a BG pseudo-junction structure.

## 3. Bond graph pseudo-junction structure

Let a given lumped system modelled by bond graph as shown in Fig. 3. The constitutive relations can be non-linear as well as linear and in both cases the junction structure is the same. In this physical system, power is conserved, energy is dissipated at the  $R$  element and all the conjugate variables are power variables. If this system is interconnected with another system through active bonds or if it includes modulated sources of energy, the overall system might be non-conservative, still having a junction structure description that in general,

- 1) Does not satisfy energy conservation properties  $P1$  to  $P2$
- 2) Has a dissipative field that may not be passive.

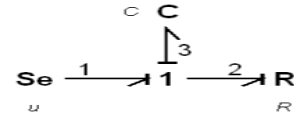

Figure 3. RC model

In the following Lemma, the construction of a pseudo-junction structure associated with a given BG is given. Also, this Lemma requires that the number of storage elements be equal to the number of dissipative elements. This condition can be achieved by,

- 1) Connecting high resistors in parallel to each  $C$  or connecting small capacitors in parallel to each  $R$ , as required, and
- 2) Connecting small resistors in serial to each of the storage elements  $L$  or connecting small inductors in serial to each  $R$ , as required.

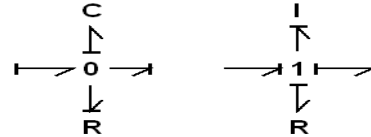

Figure 4. Augmenting the BG model using parasitic elements.

When small capacitors or inductors are added, the augmented system is singularly perturbed and the added fast dynamics must be stable accordingly to Tikhonov's Theorem (see [Kokotovic *et al.*, 1999]). This building proposition is shown in Fig. 4 where a predefined integral causality assignment is realized. So, the strong bonds impose the causality to all the elements connected to this junctions and assures that,

$$e_R = e_C \text{ and } f_R = f_I \quad (2)$$

Hence, since it is realized for each pair of  $R-C$  and  $R-I$ , then,

$$S_{22} = 0, S_{23} = 0 \text{ and } S_{21} = \mathcal{I}_n \quad (3)$$

and property P3 is achieved, that is, there are no direct causal paths between the  $R$  elements. Also, Fig. 4 implies that  $S_{12} = -\mathcal{I}_n$  for conservative systems. However, it does not hold for non-conservative systems.

**Lemma 1.** Let a given outer pseudo-junction structure  $\hat{S}^o$  defined by,

$$\begin{bmatrix} \dot{x}(t) \\ D_i(t) \\ y(t) \end{bmatrix} = \begin{bmatrix} S_{11} & S_{12} & S_{13} \\ \mathcal{I}_n & 0 & 0 \\ S_{31} & S_{32} & S_{33} \end{bmatrix} \begin{bmatrix} z(t) \\ D_o(t) \\ u(t) \end{bmatrix} \quad (4)$$

where  $x(t) \in \mathbb{R}^{n \times 1}$ ,  $D_i(t) \in \mathbb{R}^{q \times 1}$ ,  $z(t) = \phi(x(t)) \in \mathbb{R}^{n \times 1}$ ,  $D_o(t) = \psi(D_i(t)) \in \mathbb{R}^{n \times 1}$  and  $S_{12}$  is a non-singular matrix. Then, an inner pseudo-junction structure  $\hat{S}^i$  satisfying the energy conservation properties P1 to P3 is,

$$\begin{bmatrix} \dot{x}(t) \\ D_i(t) \\ y(t) \end{bmatrix} = \begin{bmatrix} 0 & -\mathcal{I}_n & S_{13} \\ \mathcal{I}_n & 0 & 0 \\ \Phi & -S_{32}S_{12}^{-1} & S_{33} \end{bmatrix} \begin{bmatrix} z(t) \\ \hat{D}_o(t) \\ u(t) \end{bmatrix} \quad (5)$$

where  $\hat{D}_o(t) \in \mathbb{R}^{n \times 1}$ ,  $\Phi := S_{31} - S_{32}S_{12}^{-1}S_{11}$ , and the multiport-coupled dissipative field is defined by,

$$\hat{D}_o(t) := -S_{12}\psi(D_i(t)) - S_{11}D_i(t) \quad (6)$$

Moreover, the system is passive if,

$$\int_0^t D_i^T(\tau) \hat{D}_o(\tau) d\tau \geq 0 \quad (7)$$

**Proof.** Since  $S_{12}$  is a non-singular matrix, from the definition of the dissipative field,

$$\psi(D_i(t)) = -S_{12}^{-1}(\hat{D}_o(t) + S_{11}D_i(t)) \quad (8)$$

Hence, from the outputs of  $\hat{S}^o$  in Eq. (4),  $z(t) = D_i(t)$ , and substituting it into the Eq. of  $\dot{x}(t)$  given by Eq. (4),

$$\dot{x}(t) = S_{11}D_i(t) + S_{12}\psi(D_i(t)) + S_{13}u(t) \quad (9)$$

Then using the definition of the dissipative field given in Eq. (6) the result of  $\dot{x}(t)$  in Eq. (5) follows. So, using  $D_i(t) = z(t)$  into Eq. (8),

$$\psi(D_i(t)) = -S_{12}^{-1}S_{11}z(t) - S_{12}^{-1}\hat{D}_o(t) \quad (10)$$

Hence, from  $y(t) = S_{31}z(t) + S_{32}\psi(D_i(t)) + S_{33}u(t)$  and Eq. (10) the result of  $y(t)$  in Eq. (5) follows. Clearly, Eq. (5) satisfy properties P1 to P3. For non-conservative systems, the stored power is not equal to the dissipated power, that is,

$$\dot{x}^T(t)z(t) + D_i^T(t)D_o(t) \neq 0 \quad (11)$$

when the input  $u(t) = 0$ . Equivalently, the total energy is not conserved. However, due to  $\hat{S}^i$  satisfying properties P1 to P3, the total energy  $c^2$  is conserved in  $\hat{S}^i$ , i.e.,

$$\int_0^t (\dot{x}^T(\tau)z(\tau) + D_i^T(\tau)\hat{D}_o(\tau))d\tau = c^2 \quad (12)$$

and only the dissipative field given by Eq. (6) may not be passive. Thus, to assure that the total energy is conserved in  $\hat{S}^o$ , this dissipative field must satisfy inequality (7).  $\square$

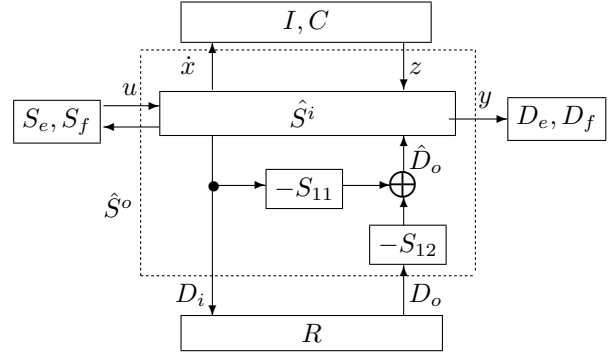

Figure 5. Detailed equivalent pseudo-junction structure where  $z(t) = \phi(x(t))$  and  $D_o(t) = \psi(D_i(t))$ .

A detailed representation of the proposed BG pseudo-junction structure is given in Fig. 5. The inner pseudo-junction structure  $\hat{S}^i$  with variables  $(\dot{x}(t), z(t))$  and  $(D_i(t), \hat{D}_o(t))$  at its interface is power conservative, when the input  $u(t) = 0$ . This is equivalent to properties P1 and P2 being satisfied as shown in Eq. (5). The matrix  $S_{11}$  of Eq. (6) and Fig. 5 is analogous to the power scaling transformers and gyrators proposed by [Li and Ngwompo, 2005], used in the passification of mechatronic systems. So, the energy conservation can be regarded as being with respect to some power scaling in the dissipative field. Therefore, the stability of the system related to the outer pseudo-junction structure  $\hat{S}^o$  can be analysed from passivity properties of the dissipative field and power-conservation. In the linear case, the passivity of the dissipative field is related to the positive semi-definiteness of the matrix defining the constitutive relationship of the field. However if the dissipative field is non-linear, the determination of the passivity will require that inequality (7) of Lemma 1 must be satisfied.

Lemma 1 gives a way to recover the physical variables leading to the outer structure  $\hat{S}^o$ . It is well known that the junction structure description is not unique, that is, there are several junction structures for the same BG. In the linear case and for systems described by state space realizations, a BG pseudo-junction structure is proposed in the work of [Gonzalez and Galindo, 2009].

The following example applies the results of Lemma 1 to a two-mass-spring-damper linear time invariant conservative system.

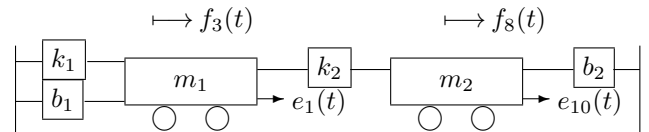

Figure 6. Two-cart system

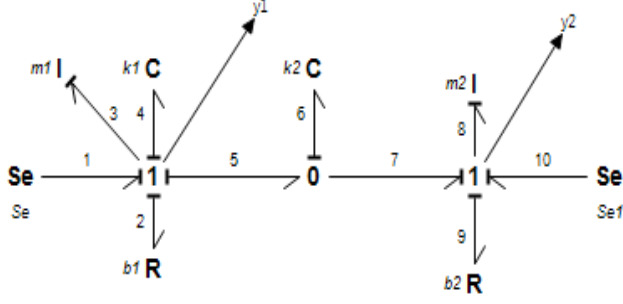

Figure 7. Bond graph of a two mass spring damper system

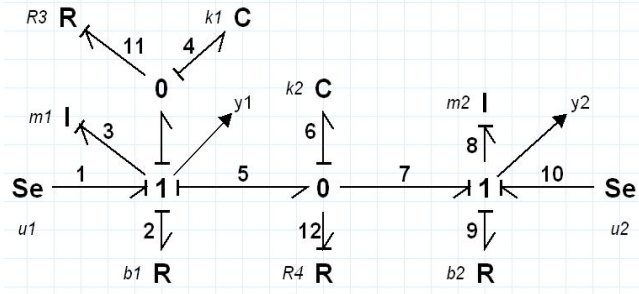

Figure 8. Augmented bond graph of a two mass spring damper system

**Example 1.** Consider the two-mass-spring-damper system shown in Fig. 6, where  $m_i$ ,  $k_i$  and  $b_i$ ,  $i = 1, 2$ , are the mass, the elasticity and friction coefficients, respectively,  $e_1(t)$  and  $e_{10}(t)$  are forces applied to masses  $m_1$  and  $m_2$ , respectively, and  $f_3(t)$  and  $f_8(t)$  are the velocities of the masses  $m_1$  and  $m_2$ , respectively. The bond graph model of this system is shown in Fig. 7 where  $f_3 = \frac{1}{m_1}p_3$ ,  $f_8 = \frac{1}{m_2}p_8$ ,  $e_4 = k_1q_4$ ,  $e_6 = k_2q_6$ ,  $e_2 = b_1f_2$  and  $e_9 = b_2f_9$ . In order to apply Lemma 1, ensuring that Fig. 4 is satisfied, first high gain resistors  $R_3$  and  $R_4$  are added as show in Fig. 8. The junction structure equation of this augmented bond graph is,

$$\begin{bmatrix} \dot{x}(t) \\ D_i(t) \\ y(t) \end{bmatrix} = \begin{bmatrix} S_{11} & -\mathcal{I}_4 & S_{13} \\ \mathcal{I}_4 & 0 & 0 \\ S_{31} & 0 & 0 \end{bmatrix} \begin{bmatrix} z(t) \\ D_o(t) \\ u(t) \end{bmatrix} \quad (13)$$

where  $S_{11} = \begin{bmatrix} 0 & 0 & -1 & -1 \\ 0 & 0 & 0 & 1 \\ 1 & 0 & 0 & 0 \\ 1 & -1 & 0 & 0 \end{bmatrix}$ ,  $S_{13} = \begin{bmatrix} \mathcal{I}_2 \\ 0 \end{bmatrix}$ ,

$S_{31} = [\mathcal{I}_2 \ 0]$ ,  $\dot{x}(t) = [e_3 \ e_8 \ f_4 \ f_6]^T$ ,  $D_i(t) = [f_2 \ f_9 \ e_{11} \ e_{12}]^T$ ,  $y(t) = [f_3 \ f_8]^T$ ,  $z(t) = [f_3 \ f_8 \ e_4 \ e_6]^T$ ,  $D_o(t) = [e_2 \ e_9 \ f_{11} \ f_{12}]^T$  and  $u(t) = [e_1 \ e_{10}]^T$ . From Lemma 1,  $\Phi = S_{31}$ , so, an inner pseudo-junction structure  $\hat{S}^i$  satisfying the energy conservation properties P1 to P3 is,

$$\begin{bmatrix} \dot{x}(t) \\ D_i(t) \\ y(t) \end{bmatrix} = \begin{bmatrix} 0 & -\mathcal{I}_4 & S_{13} \\ \mathcal{I}_4 & 0 & 0 \\ S_{31} & 0 & 0 \end{bmatrix} \begin{bmatrix} \hat{z}(t) \\ \hat{D}_o(t) \\ u(t) \end{bmatrix} \quad (14)$$

and from Eq. (6) the dissipative field is,

$$\hat{D}_o(t) = \begin{bmatrix} b_1 & 0 & 1 & 1 \\ 0 & b_2 & 0 & -1 \\ -1 & 0 & \frac{1}{R_3} & 0 \\ -1 & 1 & 0 & \frac{1}{R_4} \end{bmatrix} D_i(t) \quad (15)$$

As expected, the system is passive since the associated matrix of this dissipative field can be decomposed into a positive definite matrix  $\text{diag}\{b_1, b_2, \frac{1}{R_3}, \frac{1}{R_4}\}$  plus a skew symmetric matrix  $-S_{11}$ . So, inequality (7) is satisfied due to  $D_i^T(t)S_{11}D_i(t) = 0$ ,  $\forall D_i(t) \neq 0$ . Also, the augmented bond graph or equivalently  $\hat{S}^i$  plus the multiport-coupled dissipative field given by Eq. (15) approaches the original system modelled by the bond graph in Fig. 7 as  $R_3$  and  $R_4$  tend to infinity.  $\square$

The following example is equivalent to the one given in Fig. 4 of [Li and Ngwompo, 2005] that uses power scaling transformers and gyrators modelling an internal modulated source of energy. Here, it is regarded as the feedback interconnection of two linear time invariant systems in order to apply the results of Lemma 1. Active bonds are used for this interconnection leading to an overall system that might be non-conservative.

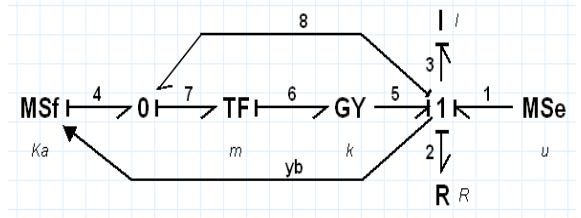

Figure 9. BG of a feedback system

**Example 2.** An illustrative example of a feedback system is given in which the controller is a single flow source of gain  $K_a = \rho - 1$  modulated by the output, as shown in Fig. 9. This example is equivalent to the one given in Fig. 4 of [Li and Ngwompo, 2005] where the power scaling transformer is replaced by the modulated source and a single transformer with modulus  $m = 1$ , a gyrator modulus  $k = 1$  and a small resistance  $R$  is added connected in cascade with the inductance according to Fig. 4. From Fig. 9,  $e_2 = u_1 - e_3 - e_8 + km(u_4 + f_2)$  and  $e_8 = e_7 = mkf_2$ , hence the junction structure of the open loop system is,

$$\begin{bmatrix} e_2 \\ f_3 \\ y(t) \end{bmatrix} = \begin{bmatrix} 0 & -1 & 1 & km \\ 1 & 0 & 0 & 0 \\ 1 & 0 & 0 & 0 \end{bmatrix} \begin{bmatrix} f_2 \\ e_3 \\ u(t) \\ u_4(t) \end{bmatrix} \quad (16)$$

Since  $u_4 = (\rho - 1)f_2$  the closed loop outer pseudo-junction structure  $\hat{S}^o$  is,

$$\begin{bmatrix} e_2 \\ f_3 \\ y(t) \end{bmatrix} = \begin{bmatrix} km(\rho - 1) & -1 & 1 \\ 1 & 0 & 0 \\ 1 & 0 & 0 \end{bmatrix} \begin{bmatrix} f_2 \\ e_3 \\ u(t) \end{bmatrix} \quad (17)$$

Applying Lemma 1,  $\Phi = 1$ , then the closed loop inner pseudo-junction structure  $\hat{S}^i$  is given by Eq. (4) where from Eq. (6) the dissipative field is,

$$\hat{D}_o(t) = (R - km(\rho - 1))f_3 \quad (18)$$

As  $R$  tends to 0,

$$\hat{D}_o(t) = km(1 - \rho)f_3 \quad (19)$$

Thus, the feedback system is passive if  $\rho 1$  as previously stated in [Li and Ngwompo, 2005], however, in [Li and Ngwompo, 2005] feedback interconnections are not covered.  $\square$

The following example applies the results of Lemma 1 to the feedback interconnection of two non-linear systems that might be non-conservative.

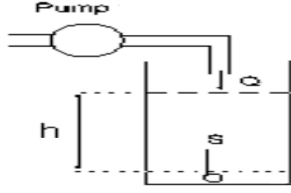

Figure 10. A tank system.

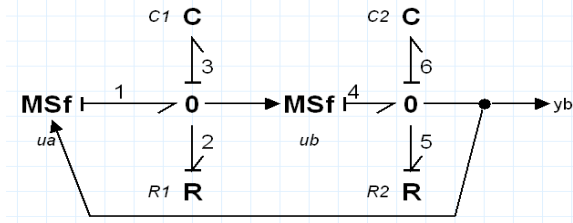

Figure 11. BG of two  $R - C$  systems interconnected in feedback.

**Example 3.** Consider the tank system shown in Fig. 10 where  $Q(t)$  is the supplying flow rate in  $m^3/sec.$ ,  $h(t)$  is the liquid level in meters and  $S$  the section of the flow leak in  $m^2$ . Let  $A$  be the cross section of the tank in  $m^2$ ,  $g$  be the earth gravity,  $\rho$  be the flow density, and  $\theta_1, \dots, \theta_4$  be real constant parameters. This tank is modelled by the  $R2 - C2$  system in Fig. 11 where,

$$h(t) = \frac{e_6}{\rho g} = \frac{q_6}{A} = -\theta_3 y_b(t) + \theta_4, \quad (20)$$

$$Q(t) = f_4 = \theta_3 A (\theta_1 u_b(t) + \theta_2) \text{ and} \quad (21)$$

$$Q_0(t) = f_5 = z_0 S \left( \frac{2e_6}{\rho} \right)^{1/2} \quad (22)$$

with  $y_b(t)$  being the output in volts of a liquid level meter,  $u_b(t)$  being the input in volts of the pump that modulates the flow source in Fig. 11,  $Q_0(t)$  being the liquid leakage flow and  $0 \leq z_0 \leq 1$  the proportion of leakage. Let  $R1 - C1$

in Fig. 11 be a proposed model for the controller where analogously to the tank system,

$$\begin{aligned} h_K(t) &= \frac{e_3}{\rho g} = \frac{q_3}{A} = -\theta_3 y_a(t) - \frac{\theta_3 \theta_2}{\theta_1 K_b}, \\ f_2 &= z_1 S \left( \frac{2e_3}{\rho} \right)^{1/2} \text{ and} \\ f_1 &= \theta_3 A (\theta_3 u_a(t) + \theta_4) \end{aligned} \quad (23)$$

where  $z_1$  is a control parameter, and  $u_a(t)$  and  $y_a(t)$  are in volts. These two  $R - C$  systems have a feedback interconnection as shown in Fig. 11 where  $u_a(t) = -y_b(t)$  and  $u_b(t) = K_b y_a(t)$  with  $K_b$  being the gain of the modulated source of flow. Hence,

$$\begin{aligned} f_1 &= \frac{\theta_3 A}{\rho g} e_6 \\ f_4 &= \frac{-\theta_1 A K_b}{\rho g} e_3 \end{aligned} \quad (24)$$

The BG of Fig. 11 satisfies Fig. 4 and the number of dissipative elements is equal to the storage elements. So, no parasitic elements are needed to apply Lemma 1. The junction structures of the interconnected sub-systems are,

$$\begin{aligned} \begin{bmatrix} f_3 \\ e_2 \\ e_3 \end{bmatrix} &= \begin{bmatrix} 0 & -1 & 1 \\ 1 & 0 & 0 \\ 1 & 0 & 0 \end{bmatrix} \begin{bmatrix} e_3 \\ f_2 \\ f_1 \end{bmatrix} \text{ and} \\ \begin{bmatrix} f_6 \\ e_5 \\ e_6 \end{bmatrix} &= \begin{bmatrix} 0 & -1 & 1 \\ 1 & 0 & 0 \\ 1 & 0 & 0 \end{bmatrix} \begin{bmatrix} e_6 \\ f_5 \\ f_4 \end{bmatrix} \end{aligned} \quad (25)$$

So, an outer pseudo-junction structure  $\hat{S}^o$  for the feedback interconnection is,

$$\begin{bmatrix} \dot{x}(t) \\ D_i \\ f_5 \end{bmatrix} = \begin{bmatrix} S_{11} & -\mathcal{I}_2 \\ \mathcal{I}_2 & 0 \\ S_{31} & 0 \end{bmatrix} \begin{bmatrix} z(t) \\ D_o(t) \end{bmatrix} \quad (26)$$

where  $S_{11} := \begin{bmatrix} 0 & \frac{\theta_3 A}{\rho g} \\ -\frac{\theta_1 A K_b}{\rho g} & 0 \end{bmatrix}$ ,  $S_{31} = \begin{bmatrix} 0 & \frac{1}{\rho g} \end{bmatrix}$ ,

$\dot{x}(t) := \begin{bmatrix} f_3 & f_6 \end{bmatrix}^T$ ,  $D_i(t) := \begin{bmatrix} e_2 & e_5 \end{bmatrix}^T$ ,  $z(t) := \begin{bmatrix} e_3 & e_6 \end{bmatrix}^T$  and  $D_o(t) := \begin{bmatrix} f_2 & f_5 \end{bmatrix}^T$ , that does not satisfy property P1. Applying Lemma 1,  $\Phi = S_{31}$ , so, an inner pseudo-junction structure  $\hat{S}^i$  for the feedback interconnection of these  $R - C$  systems is,

$$\begin{bmatrix} \dot{x}(t) \\ D_i(t) \\ f_5 \end{bmatrix} = \begin{bmatrix} 0 & -\mathcal{I}_2 \\ \mathcal{I}_2 & 0 \\ S_{31} & 0 \end{bmatrix} \begin{bmatrix} \hat{z}(t) \\ \hat{D}_o(t) \end{bmatrix} \quad (27)$$

where from Eq. (6) the multiport-coupled dissipative field is,

$$\hat{D}_o(t) = \begin{bmatrix} z_1 S \left( \frac{2e_3}{\rho} \right)^{1/2} - \frac{\theta_3 A}{\rho g} e_5 \\ z_0 S \left( \frac{2e_6}{\rho} \right)^{1/2} + \frac{\theta_1 A K_b}{\rho g} e_2 \end{bmatrix} \quad (28)$$

Selecting,

$$K_b = \frac{\theta_3}{\theta_1} \quad (29)$$

then, the cross-terms of inequality (7) are cancelled and the system is passive if,

$$\int_0^t D_i^T(\tau) \hat{D}_o(\tau) d\tau = S \left(\frac{2}{\rho}\right)^{1/2} \int_0^t \left(z_1 e_2 (e_2)^{1/2} + z_0 e_5 (e_5)^{1/2}\right) d\tau \geq 0 \quad (30)$$

These terms are the dissipative powers of the controller and the plant. So, the feedback system is passive for all  $0 \leq z_1 \leq 1$  and the designer can tune  $z_1$  adding damping and achieving the desired performance, where  $z_1 = 0$  is analogous to a completely closed and  $z_1 = 1$  to an completely open leak valve, respectively.

This non-linear controller is implemented on MatLab-Simulink in the feedback configuration of Fig. 11 as shown in Fig. 12. The tank-system parameters are  $g = 9.81 \text{ m/s}^2$ ,  $\rho = 1000 \text{ kg/m}^3$ ,  $z_0 = 1$  for a completely open leakage valve,  $S = 0.05 \times 10^{-3} \text{ m}^2$ ,  $A = 0.0154 \text{ m}^2$ , and the pump and sensor parameters are  $\theta_1 = 0.0103$ ,  $\theta_2 = 0.1022$ ,  $\theta_3 = 0.0338143$  and  $\theta_4 = 0.3115872$ . For safety, a saturation function for the plant input,

$$\text{sat}(u_b(t)) = \begin{cases} \nu & \text{if } u_b(t) > \nu \\ u_b(t) & \text{if } |u_b(t)| \leq \nu \\ -\nu & \text{if } u_b(t) < -\nu \end{cases} \quad (31)$$

is considered, where  $\nu = 0.11667 \times 10^{-3} \text{ m}^3/\text{s}$ . The control parameter  $K_b$  is given by Eq. (29), the initial conditions  $h(0) = 0.4$  for the plant and  $h_K(0) = 0$  for the controller are considered, and the parameter  $z_1$  is given the values 0.05, 0.1 and 0.2 in figures 13 and 14. The regulation problem is investigated. The outputs are smooth and stable due to the feedback system being passive. Fig. 13 shows that  $h(t)$  converges to zero for  $z_1 = 0.05$  and Fig. 14 shows that increasing  $z_1$  the damping is increased reducing the magnitude of the  $u_b(t)$  undershoot.  $\square$

## 4. Conclusions

A Bond Graph (BG) pseudo-junction structure is proposed for non-linear and non-conservative systems. This BG pseudo-junction structure has an inner pseudo-junction

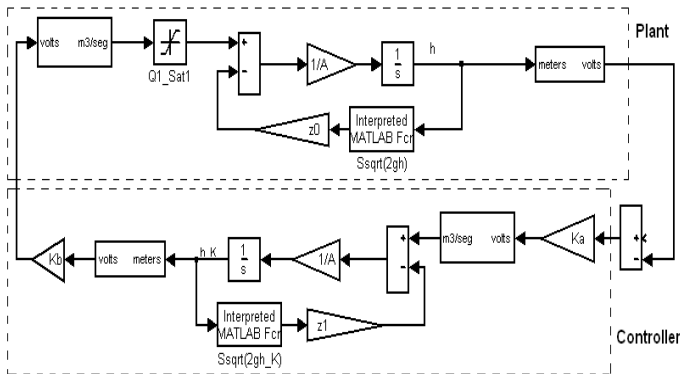

Figure 12. Non-Linear controller applied to a tank system in the feedback configuration.

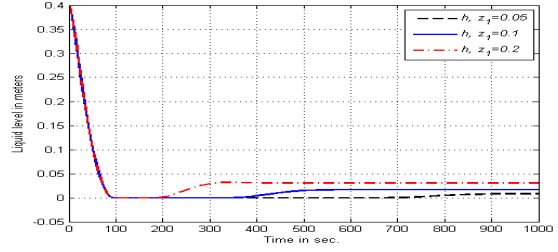

Figure 13. Tank liquid level output  $h(t)$  in the feedback configuration.

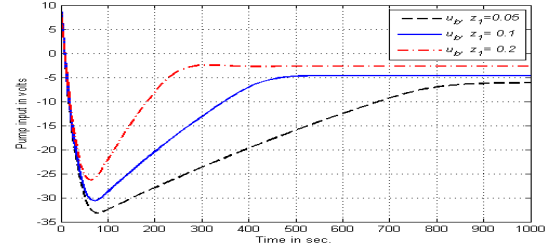

Figure 14. Pump voltage input  $u_b(t)$  in the feedback configuration.

structure that satisfies energy conservation properties, and a multiport-coupled dissipative field that determines the physical realisability of the system. The proposed BG pseudo-junction structure allows to model a large class of systems than the standard BG models. The results show that this BG pseudo-junction structure is useful for the interconnection of systems through active bonds and for passive-based control design. So, the proposed BG pseudo-junction structure has potential applications in control theory for analysis, design and optimization.

## References

- [Gawthrop, 1995] P. J. Gawthrop. Physical model-based control: A bond graph approach. *Journal of the Franklin Institute - Engineering and Applied Mathematics*, 332(3):285–305, 1995.
- [Gonzalez and Galindo, 2009] G. Gonzalez and R. Galindo. Removing the algebraic loops of a bond graph model. *Proc. of the Institution of Mechanical Engineers Part I: J. of Systems and Control Engineering*, 222(16):543–556, 2009.
- [Karnopp and Rosenberg, 1975] D. Karnopp and R. Rosenberg. *System Dynamics: A Unified Approach*. John Wiley and Sons, 1975.
- [Kokotovic et al., 1999] P. Kokotovic, H. K. Khalil, and J. O'Reilly. *Singular Perturbations Methods in Control: Analysis and Design*. Society for Industrial and Applied Mathematics, 1999.
- [Lamb et al., 1997] J. D. Lamb, D.R. Woodall, and G. M. Asher. Bond graphs ii: Causality and singularity. *Discrete Applied Mathematics*, 73:143–173, 1997.
- [Li and Ngwompo, 2005] P. Y. Li and R. F. Ngwompo. Power scaling bond graph approach to the passivation of mechatronic systems-with application to electrohydraulic valves. *ASME J. of Dynamic Systems, Measurement and Control*, 127(4):633–641, 2005.
- [Sueur and Dauphin-Tanguy, 1989] C. Sueur and G. Dauphin-Tanguy. Structural controllability / observability of linear systems represented by bond graphs. *Journal of Franklin Institute*, 326:869–883, 1989.