



Citation for published version:

Pei, X, Smith, AC & Shuttleworth, R 2016, 'Experimental Tests of a Resistive SFCL Integrated with a Vacuum Interrupter', *IEEE Transactions on Applied Superconductivity*, vol. 26, no. 3, 7422757.
<https://doi.org/10.1109/TASC.2016.2537144>

DOI:

[10.1109/TASC.2016.2537144](https://doi.org/10.1109/TASC.2016.2537144)

Publication date:

2016

Document Version

Peer reviewed version

[Link to publication](#)

© 2016 IEEE. Personal use of this material is permitted. Permission from IEEE must be obtained for all other users, including reprinting/ republishing this material for advertising or promotional purposes, creating new collective works for resale or redistribution to servers or lists, or reuse of any copyrighted components of this work in other works.

University of Bath

Alternative formats

If you require this document in an alternative format, please contact:
openaccess@bath.ac.uk

General rights

Copyright and moral rights for the publications made accessible in the public portal are retained by the authors and/or other copyright owners and it is a condition of accessing publications that users recognise and abide by the legal requirements associated with these rights.

Take down policy

If you believe that this document breaches copyright please contact us providing details, and we will remove access to the work immediately and investigate your claim.

Experimental tests of a resistive SFCL integrated with a vacuum interrupter

X. Pei, A. C. Smith, *Senior Member, IEEE*, R. Shuttleworth, *Member, IEEE*

Abstract—A resistive superconducting fault current limiter (SFCL) has been developed using round magnesium diboride (MgB_2) wire. The SFCL coil was wound using an interleaved coil arrangement to minimize the total coil inductance. The SFCL coil demonstrated reliable and repeatable current limiting properties during testing. However, the wire temperature of the SFCL coil increases quickly during quench tests and several minutes are required for temperature recovery after the fault is cleared. The SFCL coil therefore was fully integrated with a vacuum interrupter to quickly remove the SFCL coil from the circuit once a fault occurred. This allowed the SFCL coil to recover quickly whilst a bypass resistor acted as the current limiting resistance. A fast-acting actuator and its control circuit were designed and built to provide automatic control for the operation of the vacuum interrupter. The SFCL with the prototype vacuum interrupter was successfully tested. The energy dissipated in the SFCL coil was significantly reduced by integrating the vacuum interrupter. The fault tests with different potential fault currents also proved that the operation of the vacuum interrupter is independent of the fault current level. This prototype demonstrated the potential of a cost-effective and compact integrated SFCL and vacuum interrupter for power system applications.

Index Terms—Magnesium diboride, MgB_2 , Superconducting fault current limiter, SFCL, Vacuum interrupter

I. INTRODUCTION

FAULT current levels in land-based power systems are generally rising because of the increase in generation capacity. Once the fault current levels exceed the capacity of the existing system equipment, expensive upgrades become necessary. In order to avoid excessively expensive equipment upgrades, research has been undertaken into the development of superconducting fault current limiters (SFCLs). Resistive SFCLs have the simplest and most compact structure [1]. Bismuth strontium calcium copper oxide (BSCCO) and yttrium barium copper oxide (YBCO) and magnesium diboride (MgB_2) have been widely researched for resistive SFCL applications. The critical current density is approximately 50 kA/cm^2 at 77 K for BSCCO, 1000 kA/cm^2

at 77 K for YBCO and 150 kA/cm^2 at 25 K for MgB_2 [2]. The major disadvantage of a resistive SFCL is that the superconducting material heats up rapidly after quenching during a fault condition and may take several seconds to several minutes to cool down and recover after the fault is cleared. The recovery characteristics for BSCCO, YBCO and MgB_2 have been extensively investigated because reducing the recovery time is important in the design of SFCL [3-7]. Hybrid SFCLs have been proposed and constructed previously [8-11]. The superconductor element and the vacuum interrupter were connected in parallel with a coil. If a fault occurs, the superconductor quenches and the current is transferred to the parallel coil. The current in the parallel coil drives the magnetic repulsion mechanism to open the vacuum interrupter. This type of SFCL has demonstrated successful operation and fast recovery of the superconductor; however, operation of the vacuum interrupter might be affected by the fault current level and it might also be difficult to coordinate this with an auto-reclosing function for example. Another hybrid SFCL using a simple solenoidal coil to operate the vacuum interrupter has been validated [12]. The operating efficiency of the solenoid coil is low however because there is no latching function.

The purpose of this paper is to explore the potential of integrating a vacuum interrupter into the resistive SFCL system and design a fast-acting actuator whose operation is independent from the fault current level and can also be latched in the open / closed position [13]. A bypass resistor is connected in parallel with the SFCL coil and the vacuum interrupter. When a fault occurs, the SFCL coil begins to quench and starts to develop a resistance. The voltage that appears across the SFCL coil then increases and can be used as the trigger signal for the vacuum interrupter actuator. A ‘voice-coil’ type actuator is designed and built to operate the vacuum interrupter. The bypass resistor acts as the fault current limiting resistance after the vacuum interrupter opens. This system operates automatically without any external signals. It is demonstrated in this paper that it is possible to operate the vacuum interrupter within a half-cycle of the onset of the fault current. This paper presents the work conducted on the design, built and test of a resistive SFCL with an integrated vacuum interrupter. The design of vacuum interrupter actuator is also presented.

II. SFCL COIL AND TEST CIRCUIT

A. SFCL coil manufacture process

The SFCL coil was manufactured using a round MgB_2 wire

Manuscript received August 24, 2015. The authors would like to thank Rolls-Royce plc. for their support. Thanks are also due to Hyper Tech Research, Inc. for providing the MgB_2 wire sample and Scientific Magnetics for the design and manufacture of the cryogenic system.

The authors are with the School of Electrical and Electronic Engineering, The University of Manchester, Manchester, M13 9PL UK. (phone: +44-161-306-4667; fax: +44-161-306-4774; e-mails: xiaoze.pei@manchester.ac.uk, sandy.smith@manchester.ac.uk, roger.shuttleworth@manchester.ac.uk).

with a diameter of 1.28 mm, provided by Hyper Tech Research, Inc. The monocoil MgB_2 wire has a niobium barrier between the MgB_2 and monel sheath. The critical current was approximately 240 A at 34 K. Ideally an SFCL coil should insert minimum impedance into the power network during normal operation. Two windings of approximately 2.5 meters each of superconducting wire were wound onto an alumina former. The two windings carry current in the opposite directions and are interleaved for voltage withstand as shown in Fig. 1 so that the main solenoidal field is cancelled to produce a low inductive coil [7, 14]. This SFCL coil was manufactured using a wind-and-react method. The SFCL coil on the alumina former was heat treated in a vacuum oven at 700 °C for 30 minutes to react the magnesium and boron power to form MgB_2 . Instrumentation was then mounted onto the coil. Voltage taps and BAS16 diode temperature sensors [15] were soldered onto the MgB_2 wire at multiple locations. Kapton tape was used to wrap the entire former and provide voltage insulation between the coil and the cryostat copper containment bucket. Fig. 1 shows the SFCL coil ready to be installed into the cryostat.

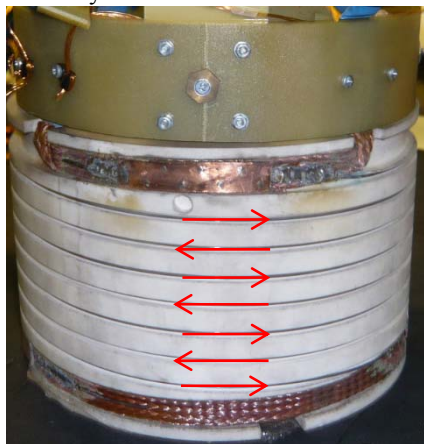

Fig. 1. MgB_2 SFCL coil

B. Test rig

A controllable high current test circuit, as shown in Fig. 2, was used to test the behavior of the SFCL coil with the integrated vacuum interrupter. A variable transformer was directly connected to the laboratory supply and its output was connected to a step-down transformer through a point-on-wave switch. The switch was used to control the number of AC cycles supplied to the test coil. It should be pointed out that the vacuum interrupter here was placed into a separate vacuum containment chamber because the test cryostat was not designed for this purpose; however, in practice the vacuum interrupter could be located within the vacuum insulation needed in the cryostat thus removing the need for a separate vacuum containment chamber around the interrupter. A variable load resistor was placed in series with the SFCL coil and the vacuum interrupter in the secondary side of the transformer, to represent the system impedance. The bypass resistor was placed in parallel with the SFCL coil and the vacuum interrupter. A switch was placed in parallel with the load resistor to simulate a fault by manually closing the switch

and short-circuiting the load resistor. The test circuit provided constant voltage rather than constant current. The MgB_2 coil would behave as a practical SFCL when transitioning from the superconducting state to the normal resistive state. The bypass resistor would be in the circuit during the fault for typically less than a hundred milliseconds. The resistor therefore is designed and rated for short-term operation, which makes it compact and relatively low-cost. Voltage, current and temperature signals were monitored and recorded during testing. Switch control and data acquisition were provided by a PC based LabVIEW system.

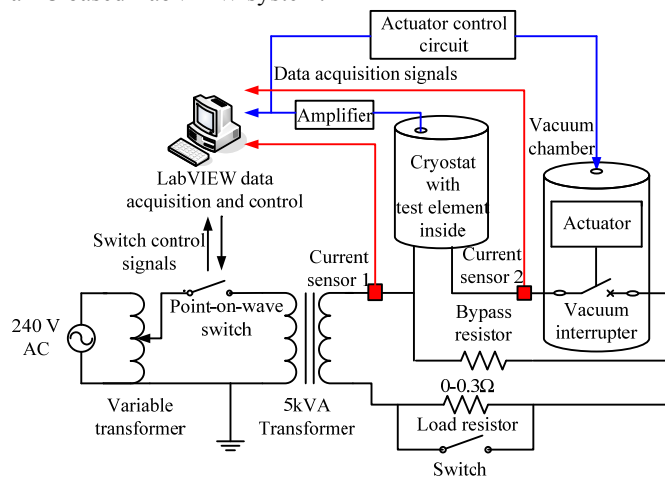

Fig. 2. Schematic of the high current test circuit

C. Vacuum Interrupter and Its Actuator

This paper proposes the integration of a vacuum interrupter into the resistive SFCL. It is important to design and build a fast-acting actuator to operate the commercial DVS10CB vacuum interrupter used here. A ‘voice-coil’ type actuator was selected and designed to provide controllable and high speed operation [16, 17]. Fig. 3 shows the prototype actuator that was designed and built for this application. This prototype actuator was successfully tested at atmospheric pressure and in the vacuum chamber. Details of the design and testing of the vacuum interrupter actuator itself are not within the scope of this paper and will be published separately.

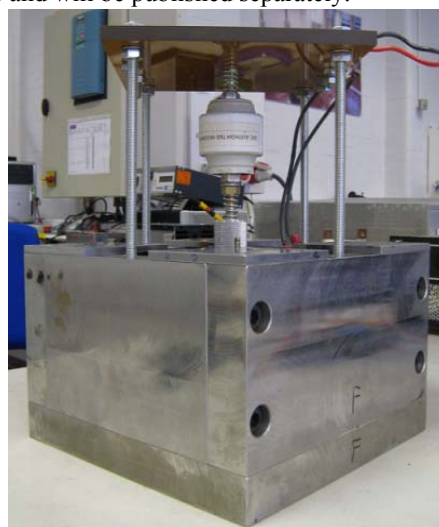

Fig. 3. Prototype actuator with commercial vacuum interrupter

III. EXPERIMENTAL RESULTS AND DISCUSSION

A. Quench tests

A quench test without the vacuum interrupter was carried out initially to test the behavior of the SFCL coil. The quench test was undertaken at 34 K to reduce the quench current level. The high current test circuit was used to pass two cycles of current. The fault current, coil current, resistor current and coil voltage during testing with a potential peak current of 324 A are shown in Fig. 4. The load resistance is 0.1 Ω . The prospective fault current for the test circuit was estimated based on the assumption that the coil was in the superconducting state and had negligible impedance. The prospective fault current therefore represents the estimated current if the SFCL was removed from the circuit. It is clear that the SFCL coil quenches at around 5 milliseconds and limits the peak fault current to 240 A in the first quarter-cycle and then reduces the peak current to 160 A over the next two cycles. The coil current is lower than the fault current because after the coil quenches, the bypass resistor shares part of the fault current.

The purpose of the quench test with the vacuum interrupter was to prove whether the operation of the vacuum interrupter would prevent the SFCL coil from heating up and hence improve recovery times. The pre-set threshold voltage level to open the vacuum interrupter is an important parameter. If the threshold voltage level is too low, it may lead to nuisance tripping of the vacuum interrupter during current transient for example. If the threshold voltage level is too high, the temperature of the coil may rise significantly before the vacuum interrupter opens. The amplitude of the coil voltage was approximately 0.2 V with normal current passing through it, which was dominated by the coil inductance. The threshold voltage level of 2V is an arbitrary figure but it was chosen to avoid nuisance tripping. Interestingly, varying the threshold voltage level provides an element of controllability to the management of the power system.

The fault current, coil current, resistor current, coil voltage and vacuum interrupter voltage of the quench test with the vacuum interrupter are also shown in Fig. 4. The voltage across the coil increases rapidly after the coil quenches. When the coil voltage is greater than the pre-set threshold voltage level of 2V, the actuator control circuit triggers the pre-charged capacitors in the actuator supply circuit and the actuator coil starts to move. The vacuum interrupter contacts start to separate in 2.5 milliseconds as shown in Fig. 4. After the contacts separate, an arc is drawn between the contacts inside the vacuum interrupter. The coil current and voltage start to reduce and the arc extinguishes naturally at the next coil current zero-crossing. The current through the coil then becomes practically insignificant and the fault current is fully transferred into the bypass resistor. The voltage across the vacuum interrupter is then determined by the voltage across the resistor. The energy dissipated and temperature rise of the SFCL coil is reduced as a result and additionally the coil starts to recover whilst the bypass resistor continues to limit the fault current. The SFCL with vacuum interrupter would allow for a

significantly faster recovery time compared to a basic resistive SFCL.

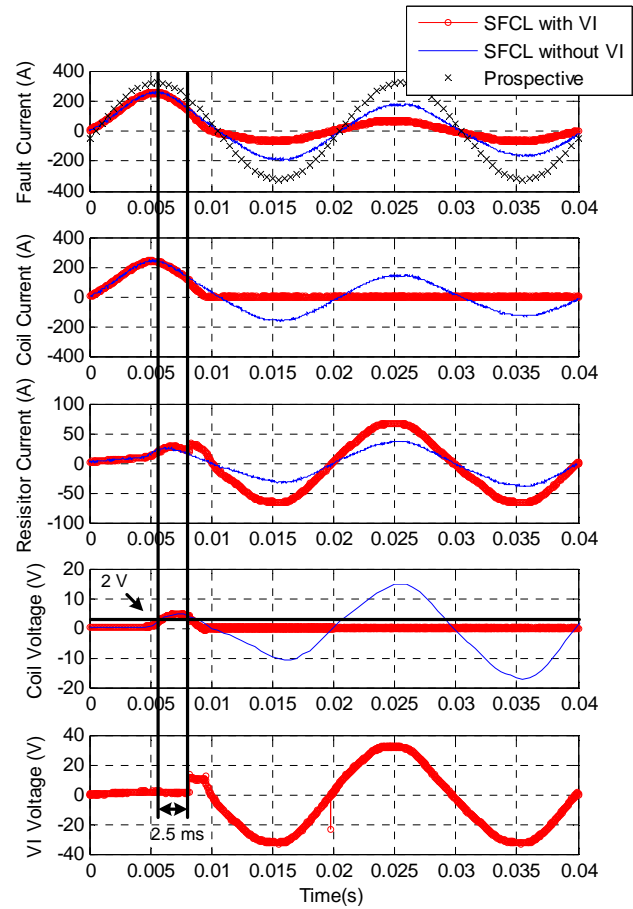

Fig. 4. Quench test with a prospective fault current of 324 A with and without the vacuum interrupter

Fig. 5 presents the temperature rise of the coil measured using a BAS16 diode temperature sensor during the quench test with and without the vacuum interrupter. The power dissipation of the coil is integrated over time to determine the energy dissipated in the coil. From the results in Fig. 4, approximately 32.3 J is dissipated in the coil for two cycles without the vacuum interrupter. The measured temperature rise of the SFCL coil was 13 K and it took approximately 55 seconds to recover to the operating temperature of 34 K. The maximum temperature was recorded after 5 seconds due to the thermal capacity between the diode temperature sensor and the MgB_2 wire. When the SFCL coil was integrated with the vacuum interrupter, the energy dissipated in the coil was reduced to 2.7 J, approximately 8% of the value without the vacuum interrupter. There was no discernible temperature rise in the coil. This demonstrates clearly that the energy dissipated in the coil is significantly reduced by quickly opening the vacuum interrupter and as a result the temperature rise of the coil is practically eliminated.

The quench test with and without the vacuum interrupter were repeated with a higher prospective fault current of 375 A to verify if the system operation would be affected by the fault

current levels. A 15% increase in the prospective fault current was used to represent a reasonable increase in the fault current without potentially damage the SFCL coil. Fig. 6 shows the fault current, coil current, resistor current, coil voltage and vacuum interrupter voltage. When the SFCL coil was tested without the vacuum interrupter, the coil quenched at around 4.5 milliseconds and limits the peak fault current to 295 A in the first quarter-cycle, reducing the peak current to 180 A over the next two cycles. When the vacuum interrupter was added, again with a threshold coil voltage of 2V, the vacuum interrupter contacts started to separate within 2.5 milliseconds as shown in Fig. 6.

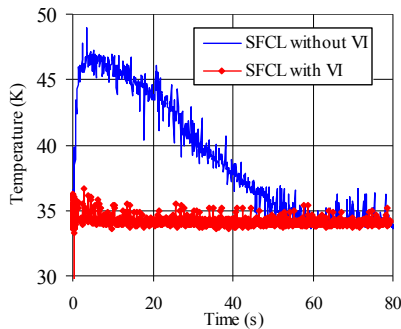

Fig. 5. Temperature rise of the coil during the quench test with a potential peak current of 324 A with and without the vacuum interrupter

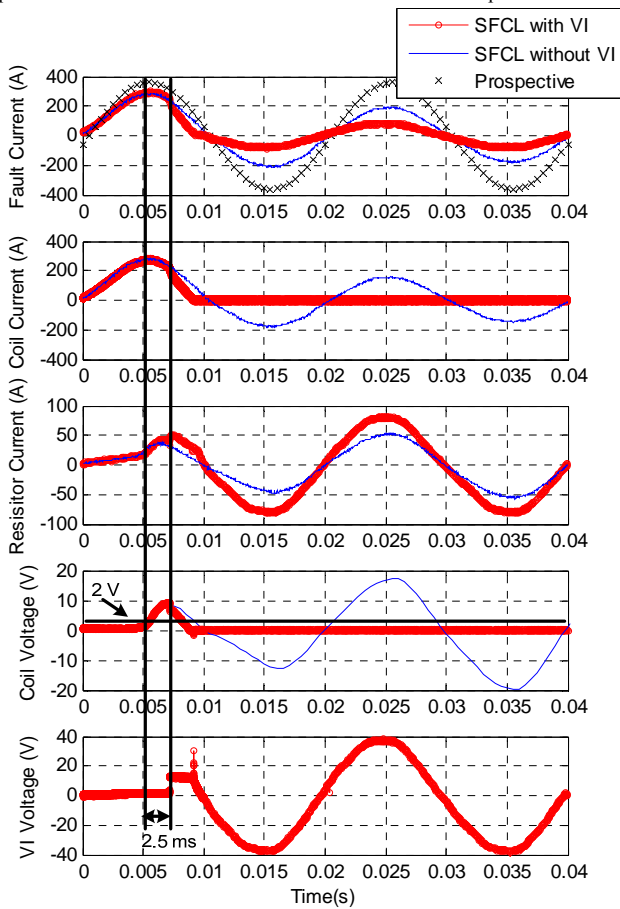

Fig. 6. Quench test with a prospective fault current of 375 A with and without the vacuum interrupter

The SFCL coil has demonstrated successful quench behavior and shown that MgB_2 wire is a potential candidate material for future SFCL development. With the integrated vacuum interrupter, the fault current was fully diverted into the bypass resistor at the next current zero-crossing after the fault was imposed. This significantly reduced the energy dissipated, temperature rise and recovery time of the coil. The repeated test with a higher potential peak current also showed that the operation of the vacuum interrupter is independent of the fault current level because the vacuum interrupter is operated by a separately controlled actuator.

Separating the actuator supply from the fault current provides the greatest system flexibility. The trigger circuit based on a threshold value for the coil voltage enables automatic operation without nuisance tripping or dependence on the fault current level. External triggering signals can also be brought in if necessary to provide full control of the operation of the SFCL/actuator unit.

B. Simulated fault test

After the SFCL coil with the vacuum interrupter demonstrated successful operation, a simulated fault test was carried out to assess the current limiting performance of the coil in a more realistic operational condition. The limiting number of AC cycles supplied was set to 20 cycles in the LabVIEW control program. Before the test, the switch in parallel with the load resistor was kept open so that normal operating current flowed in the circuit and the SFCL coil showed no measurable resistance. The switch was then manually closed to short-circuit the load resistor and simulate a fault.

The operation of the SFCL coil without the vacuum interrupter was tested initially. Fig. 7 shows the fault current, coil current, resistor current, and coil voltage from the simulated fault test. The normal operating peak current was 50 A and the switch was manually closed at approximately 0.25 seconds. The current increases rapidly and makes the coil quench. In this test it is clear that the SFCL coil quenches and limits the peak fault current to 245 A in the first quarter-cycle, then further reduces the peak current to 120 A over the next seven cycles. It is clear that the bypass resistor shares part of the fault current once the SFCL coil quenches as shown in Fig. 7. The voltage across the coil increases after quenching and 81.7 J is dissipated in the coil.

Fig. 8 shows the results from the simulated fault test with the vacuum interrupter. The normal operating peak current was 50 A again and the switch was manually closed at approximately 0.18 seconds to simulate a fault. The coil quenches due to the rising fault current and the coil voltage increases over the pre-set threshold voltage level which then triggers the actuator to open the vacuum interrupter. The SFCL coil limits the fault current during the first half cycle and then the bypass resistor operates as a current limiting resistor once the SFCL coil is isolated by the vacuum interrupter. The energy dissipated in the coil is reduced to 4.5 J, which is approximately 5.5% of the value without the vacuum interrupter.

Again the SFCL coil with the vacuum interrupter demonstrated successful operation during the simulated fault test. The energy dissipated in the coil was also greatly reduced.

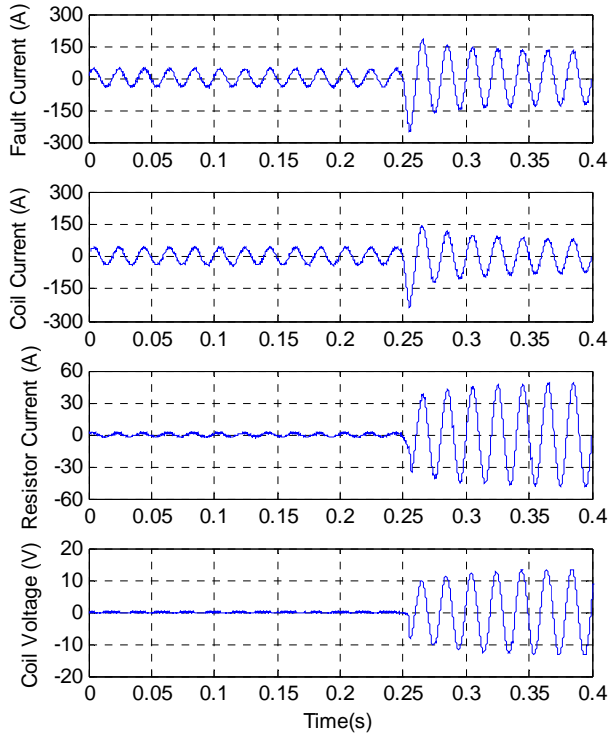

Fig. 7. Simulated fault test without the vacuum interrupter

IV. CONCLUSIONS

A resistive SFCL coil using round MgB_2 wire successfully operates as a fault current limiter. The SFCL coil demonstrated repeatable and reliable current limiting characteristics during quench tests. In order to limit the temperature rise of the MgB_2 coil and the long recovery time of the resistive SFCL, a vacuum interrupter was integrated into the existing SFCL system. A fast-acting vacuum interrupter actuator was also designed, built and demonstrated successful operation.

The SFCL coil with a vacuum interrupter operated using the fast-acting actuator demonstrated successful operation during quench tests and simulated fault tests. The energy dissipated in the coil was significantly reduced with the vacuum interrupter. This unit also demonstrated similar operation at different potential peak currents, which proved that the fault current level did not affect the operation of the vacuum interrupter. This system represents a potential resistive SFCL system that is controllable, compact and quick to recover.

ACKNOWLEDGMENT

The authors would like to thank Rolls-Royce plc. for their support. Thanks are also due to Hyper Tech Research, Inc. for providing the MgB_2 wire sample and Scientific Magnetics for

the design and manufacture of the cryogenic system.

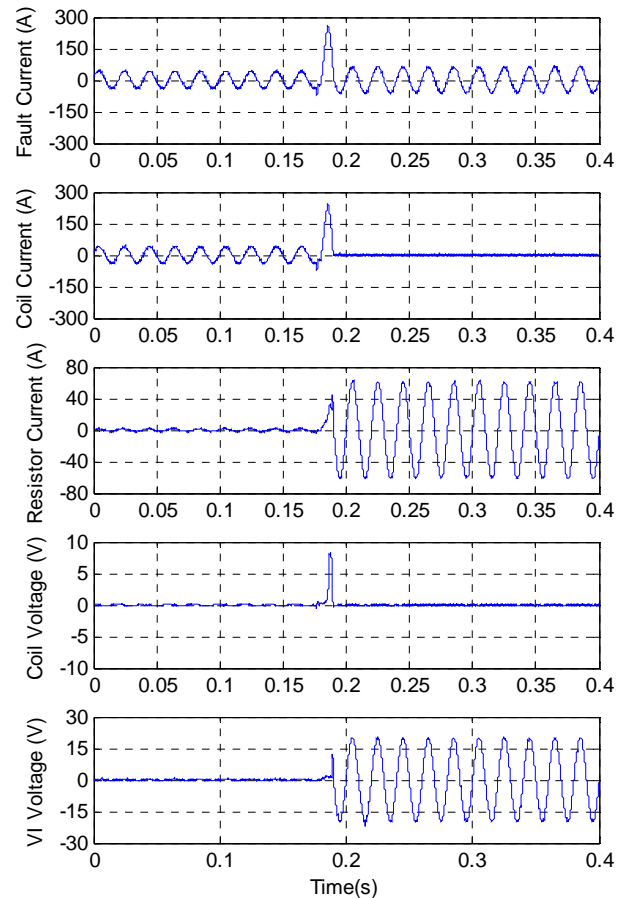

Fig. 8. Simulated fault test with the vacuum interrupter

REFERENCES

- [1] M. Noe and M. Steurer, "High-temperature superconductor fault current limiters: concepts, applications, and development status," *Supercond. Sci. and Technol.*, vol. 20, pp. R15-R29, Mar. 2007.
- [2] S. S. Kalsi, Applications of High Temperature Superconductors to Electric Power Equipment, Wiley-IEEE Press, April 2011, pp. 15-26.
- [3] M. C. Ahn, et al. "Recovery characteristics of resistive SFCL wound with YBCO coated conductor in a power system," *IEEE Trans. Appl. Supercond.*, vol. 17, pp. 1859-1862, Jun. 2007.
- [4] P. J. Costa Branco, M. E. Almeida, and J. A. Dente. "Proposal for an RMS thermoelectric model for a resistive-type superconducting fault current limiter (SFCL)," *Electric Power Systems Research*, vol. 80, pp. 1229-1239, Oct. 2010.
- [5] H. Kim, et al. "An Effect of HTS Wire Configuration on Quench Recovery Time in a Resistive SFCL," *IEEE Trans. Appl. Supercond.*, vol. 23, Jun. 2013, Art. ID. 5604104.
- [6] G. Didier, C. H. Bonnard, T. Lubin, and J. L ev eque, "Comparison between inductive and resistive SFCL in terms of current limitation and power system transient stability," *Electric Power Systems Research*, vol. 125, pp. 150-158, Aug. 2015.
- [7] A. C. Smith, A. Oliver, X. Pei, M. Husband, and M. Rindfleisch, "Experimental testing and modelling of a resistive type superconducting fault current limiter using MgB_2 wire," *Supercond. Sci. and Technol.*, vol. 25, Dec. 2012, Art. ID. 125018.
- [8] T. Hori, A. Otani, K. Kaiho, I. Yamaguchi, M. Morita, and S. Yanabu, "Study of superconducting fault current limiter using vacuum interrupter driven by electromagnetic repulsion force for commutating switch," *IEEE Trans. Appl. Supercond.*, vol. 16, pp. 1999-2004, Jun. 2006.

- [9] M. Endo, T. Hori, K. Koyama, I. Yamaguchi, K. Arai, K. Kaiho, and S. Yanabu, "Operating characteristics of superconducting fault current limiter using 24kV vacuum interrupter driven by electromagnetic repulsion switch," *J. of Phys.: Con. Ser.*, vol. 97, 2008, Art. ID. 012068.
- [10] O. B. Hyun, J. Sim, H. R. Kim, K. B. Park, S. W. Yim, and I. S. Oh, "Reliability enhancement of the fast switch in a hybrid superconducting fault current limiter by using power electronic switches," *IEEE Trans. Appl. Supercond.*, vol. 19, pp. 1843-1846, Jun. 2009.
- [11] Y. Sato, S. Arazoe, H. Anji, H. Okumo, N. Takao, and S. Yanabu, "Parallel and series operation of vacuum interrupters for circuit breakers and a superconducting fault current limiter," *IEEE Trans. Plasma Sci.*, vol. 39, pp. 1358-1363, Jun. 2011.
- [12] B. I. Jung and H. S. Choi, "Combined effect of the SFCL and solenoid coils," *IEEE Trans. Appl. Supercond.*, vol. 24, Jun. 2014, Art. ID. 5600404.
- [13] X. Pei, A. C. Smith, M. Husband, and M. Rindfleisch "Experimental tests on a superconducting fault current limiter using three-strand MgB₂ wire," *IEEE Trans. Appl. Supercond.*, vol. 22, Jun. 2012, Art. ID. 5600405.
- [14] M. Husband, A. C. Smith, R. Shuttleworth, and X. Pei, "Current limiter," European Patent, EP 2621043 A2, Jul. 2013.
- [15] A. P. Rijpma and H. J. M. ter Brake, "Cryogenic thermometry with a common diode: type BAS16," *Cryogenics*, vol. 46, pp. 68-69, 2006.
- [16] J. R. Brauer, *Magnetic actuators and sensors*. Wiley-Interscience, 2006.
- [17] J. Borwick, *Loudspeaker and headphone handbook*. London: Butterworths, 1988.