

*Citation for published version:*

Dumont, N, Watson, RJ & Pennock, SR 2011, Fine resolution simulation of TV white space availability and model validation. in *2011 IEEE Vehicular Technology Conference Fall, VTC Fall 2011 - Proceedings*. IEEE Vehicular Technology Conference, IEEE, Piscataway, NJ, IEEE 74th Vehicular Technology Conference, VTC Fall 2011, September 5, 2011 - September 8, 2011, San Francisco, CA, USA United States, 1/01/11.  
<https://doi.org/10.1109/vetecf.2011.6092970>

*DOI:*

[10.1109/vetecf.2011.6092970](https://doi.org/10.1109/vetecf.2011.6092970)

*Publication date:*

2011

*Document Version*

Peer reviewed version

[Link to publication](#)

© 2011 IEEE. Personal use of this material is permitted. Permission from IEEE must be obtained for all other uses, in any current or future media, including reprinting/republishing this material for advertising or promotional purposes, creating new collective works, for resale or redistribution to servers or lists, or reuse of any copyrighted component of this work in other works.

**University of Bath**

**Alternative formats**

If you require this document in an alternative format, please contact:  
[openaccess@bath.ac.uk](mailto:openaccess@bath.ac.uk)

**General rights**

Copyright and moral rights for the publications made accessible in the public portal are retained by the authors and/or other copyright owners and it is a condition of accessing publications that users recognise and abide by the legal requirements associated with these rights.

**Take down policy**

If you believe that this document breaches copyright please contact us providing details, and we will remove access to the work immediately and investigate your claim.

# Fine resolution simulation of TV white space availability and model validation

Nathan Dumont, Robert J. Watson and Stephen R. Pennock

Department of Electronic Engineering

University of Bath

Bath, England

Email: N.Dumont@bath.ac.uk, R.J.Watson@bath.ac.uk, S.R.Pennock@bath.ac.uk

**Abstract**—Availability of television white space is of interest for developing new data networks which operate between licensed users. The practical sensing and computational modelling of this band has been the focus of study in this and a preceding paper [1]. In this paper a high spatial resolution was used to look at the areas that a single channel was available in moderately rough terrain in the UK. The size of areas which shared available frequencies was found to be small and potential problems with spot measurements were highlighted. The practical validation of the software model with a measurement campaign has been started, the early results of this show the model to be reasonably accurate in exposed areas with little building but at portable equipment heights in streets the model shows significant variation from measured results.

## I. INTRODUCTION

Spectrum availability is of great interest to developers looking at white space radio technologies. In [1] the authors studied a large scale simulation of bandwidth availability in the south west of the UK. The study showed that the protection limit suggested by Ofcom [2] will prevent many wide-area, large-scale applications in TV white space in the UK such as IEEE 802.22 [3]. In the majority of locations a relatively small number of channels were available as sufficient signal from the numerous broadcast stations in the UK occupy most channels, and the probability of the same channels being available over wide areas is very low.

Fig. 1, taken from [1], shows the availability of links of at least 10 km between adjacent calculation cells which share an available frequency. However in each location only a spot measure was taken to generate this data and finer resolution study was required to see how realistic this area generalisation is.

In this paper smaller scale cells are investigated in order to ascertain the availability of common channels in smaller urban areas. In addition, field trials have been undertaken, measuring the radio spectrum to test the validity of the simulation model. The measurements have also made the practical implications of creating wide band sensing equipment apparent and have shown that the qualitative predictions of errors in urban terrain are accurate.

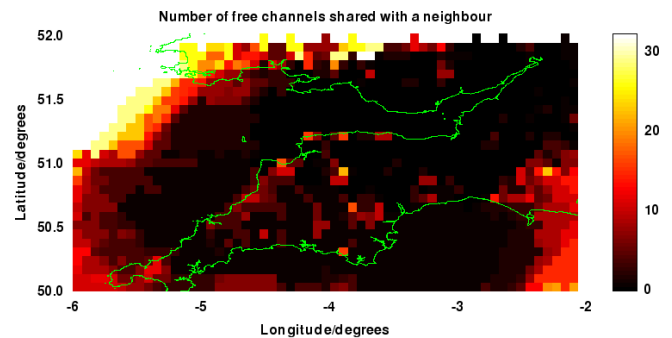

Fig. 1. Number of locations where a link of at least 10 km would be possible. Each point represents a pair of neighbouring locations which share the same free channels, so an RF link on that frequency could be safely used to connect the two locations.

## II. METHOD

### A. Simulation improvements

Simulations of the availability of the radio spectrum were made using the parabolic equation model [4] implemented to provide incoherent RF power [1], but with some improvement to the software structure to provide a higher resolution study of some smaller areas. The output from the model was presented to make the size of contiguous areas with a single channel free apparent by plotting the availability for each channel as an image rather than just a count of the number of available channels 8.

### B. Field measurements

In the previous work [1] comparison of the model results and the measurements were presented based on measurements taken with a Rohde & Schwarz FSEK30 spectrum analyser in the radio laboratory at the University of Bath. The validation of the model that this provided was limited by the terrain around the university which makes the line of sight path most dominant. To validate the model further measurements in locations relying on diffraction around terrain in various situations were required.

To acquire measurements of spectrum occupancy in a variety of areas a portable spectrum analyser with logging capability was required. The solution chosen was to implement a software spectrum analyser using an Ettus Research USRP

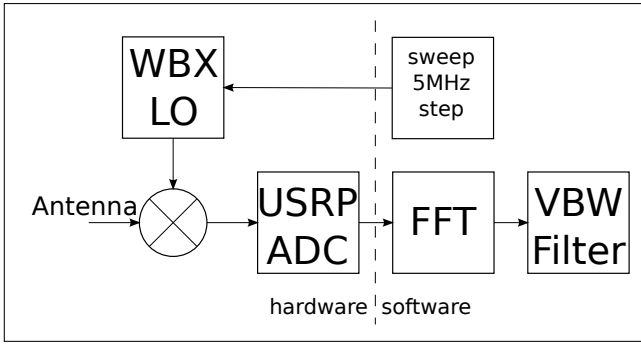

Fig. 2. Overview of the USRP based spectrum analyser implementation

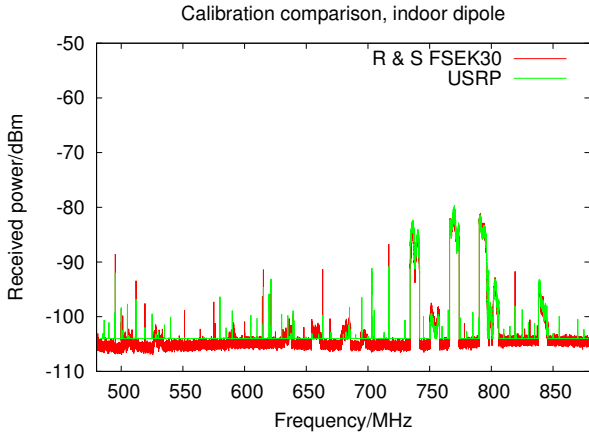

Fig. 3. Comparison of Rohde & Schwarz FSEK30 and software spectrum analyser in the band of interest, both attached to an indoor dipole antenna

N210 [5] with WBX front-end board as the hardware. The analyser application, described in Fig. 2 retrieves a number of samples at a sample rate of 10 MHz and then applies a windowed FFT to achieve a finer resolution bandwidth. Output from several of these FFTs is low pass filtered based on the requested video bandwidth.

To calibrate out amplitude non-linearity in the WBX front-end, a Rohde & Schwarz SMIQ signal generator was used to produce a CW signal at fixed frequencies and signal power, spaced at 100 kHz and 10 dBm across the band of study, the received signal power for transmitted power from -110 dBm to -60 dBm on each frequency was noted in a calibration file and later applied to compensate for the passband variations in the WBX front end board.

Once calibrated, the software was used to measure the signal received from two different antennas and compared with the spectrum produced by a Rohde & Schwarz FSEK30 spectrum analyser connected to the same antennas. The resulting comparison graphs are shown in Fig. 3 and Fig. 4. As can be seen the calibrated USRP measurements closely match the output of the FSEK spectrum analyser and so indicate that signals measured in the field should be of reasonable accuracy for simple quantitative statements.

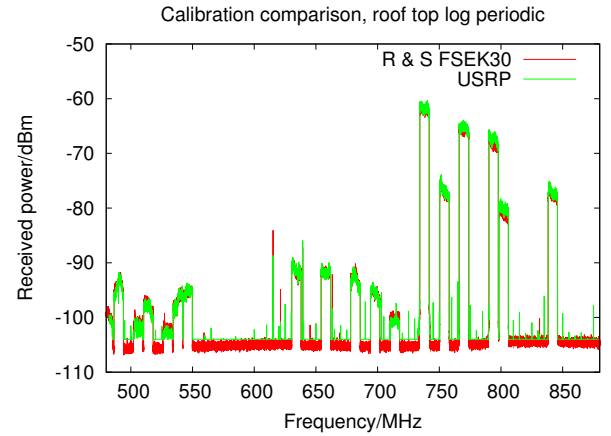

Fig. 4. Comparison of the output of Rohde & Schwarz FSEK30 spectrum analyser and the output of the software spectrum analyser in the band of interest, both were attached to a roof-top log periodic antenna.

It is also apparent from looking at the calibration graphs that the antenna used is highly significant. In both cases the antenna was pointed to receive maximum signal from the local main transmitter and polarised correctly, however the received power shown in Fig. 3 is clearly much lower. This decrease in received signal is partly due to the fact that the receive antenna was indoors, but also because a simple dipole was used for field measurements, so it is only a narrow band antenna. This will be an important concern when designing portable equipment for use in TV white space as the dipole antenna being used for measurements in the field was picked for its moderate size but it is still larger than might be considered practical for installation in portable equipment.

Fig. 5 shows a comparison of the two antenna options and the simulation results from the PEM software model at the University of Bath. It can be seen that the outdoor rooftop antenna shows better agreement with the prediction than the indoor smaller antenna. It can be seen that the small dipole antenna is typically about 25 dB lower in measured signal strength than the roof top log periodic, which has a total gain from the Mendip transmitter of around 0 dB.

### III. RESULTS

#### A. High resolution simulation

The output of the high resolution simulation (1 km per cell compared to 10 km in the original work) was presented in a variety of ways, firstly a colour map approach as used in the original work [1] was used to give an overview of total incoherent signal power in the area. Due to the smaller scale of the simulation it was practical to overlay these results with contour lines to give an idea of how the availability follows terrain. As can be seen in Fig. 6 the availability is not just in the deepest valleys but anywhere that the terrain is sharply changing. A channel was considered to be empty if the signal power in that channel was below -84 dBm. This figure is based on an Ofcom report [2] which shows this to

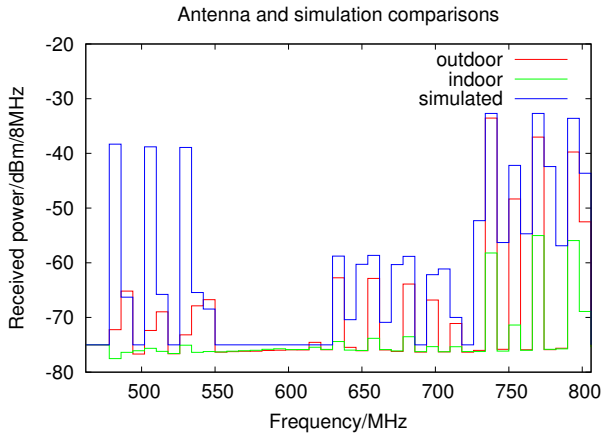

Fig. 5. Comparison of received signals with each antenna and the model data at the same site

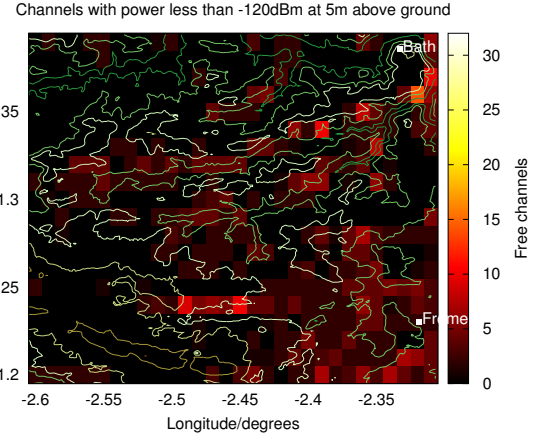

Fig. 7. Available channels with -120 dBm detection threshold

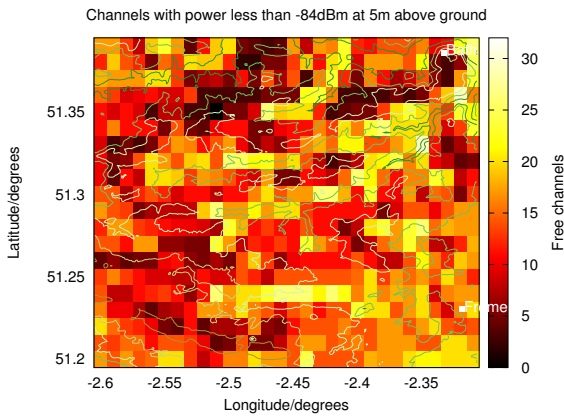

Fig. 6. Available channels at -84dBm in an area of hilly terrain near Bath, UK

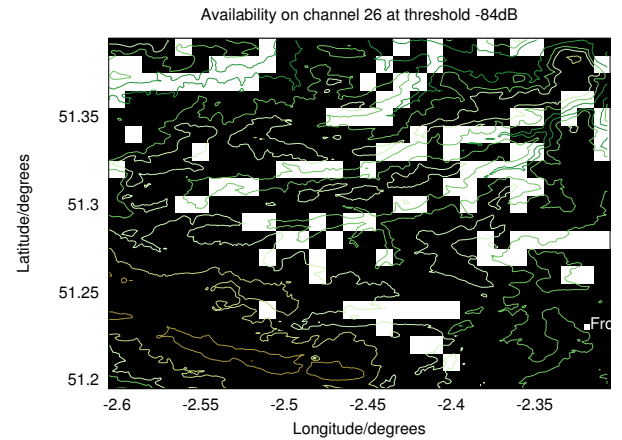

Fig. 8. Availability of a single channel in hilly terrain

be the lowest signal power a commercial DVB-T receiver can decode. Using this metric for availability assumes that a geo-location database approach is in use and there is no need for a protection threshold for direct detection of the band, this gives a typical availability of around 12 to 15 channels. Fig. 7 shows the case where a protection threshold is applied but the receiver sees little obstruction other than terrain. It can be seen in Fig. 7 that most areas have less than 5 channels available and some have none, making this a much less attractive situation for developing new equipment.

For large scale deployment of television white space technology there needs to be geographical correlation in the available channels. If one location has a number of free channels and a neighbouring location also has a number of free channels, but none of the channels are the same then two devices in the two areas cannot set up a network. Fig. 8 shows the availability of one channel based on the PEM simulation results, again a channel is considered available if the signal level is below -84 dBm.

These results show that the available spectrum in this case

is in very small pockets, the cells are roughly 1 km across in this output. The output also shows that if spectrum sensing at the device alone were to be used it is possible to see a channel as available in a number of locations and be interfering with a licensed receiver between two available points.

### B. Measurements

Measurements of the spectrum were taken at several locations around the city of Bath, sites were picked to provide a selection of urban and open environments both in exposed hill-top locations, in steep valley terrain and in built up areas.

The results gathered at the open, hill-top location support the output from the PEM code. Fig. 9 shows the measured spectrum, as was expected from the calibration results, the signal power received by the small dipole is well below what might have been expected. With the antenna horizontally polarised and oriented to receive from an east or west direction the signal received from the main Mendip transmitter is around 15 dB below the simulation, which is in line with Fig. 5. Vertically polarising the antenna very slightly improves the reception from the Bath repeater which is vertically polarised

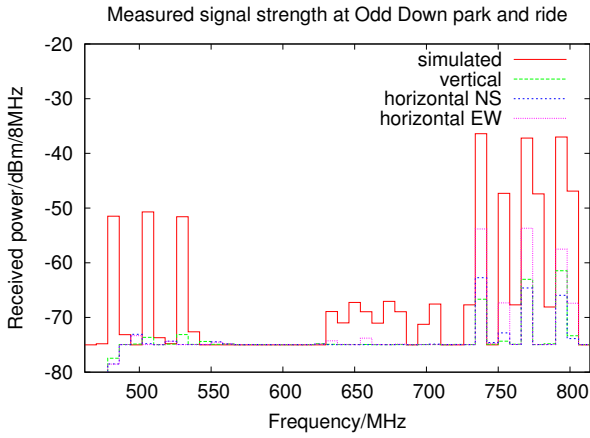

Fig. 9. Spectrum measurements from Odd Down park and ride which is an exposed hill top car park.

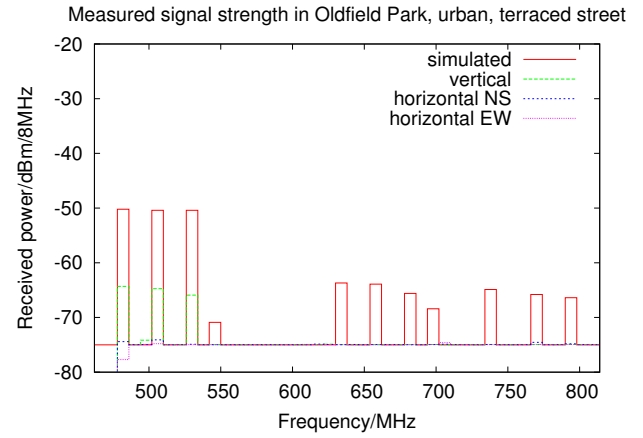

Fig. 11. Signal received in a typical British residential street with 2-3 story terraced housing either side.

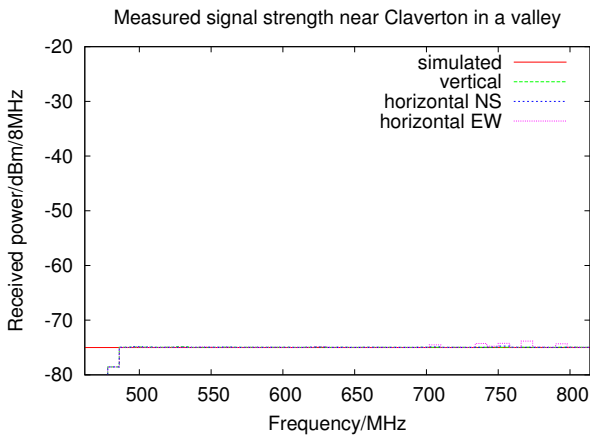

Fig. 10. Signal received in a deep valley with little population

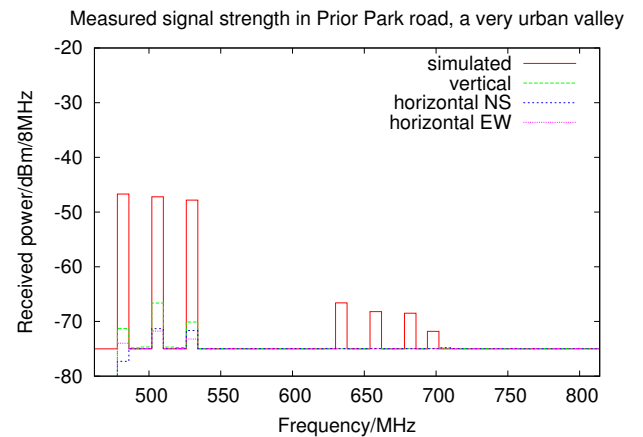

Fig. 12. Prior Park road lies at the bottom of a valley with large residential (3 to 4 story) buildings each side to the ridge.

but highlights the problem with assuming that all transmitters are omni-directional in the model as the Bath repeater is not omni-directional.

The results where the receiver was in deep valley terrain in Fig. 10 show that rather more channels are available as white space. This area is not served directly by any repeaters or main stations, further along the valley the main station at Mendip is visible. In this case the model and the measurements show no channels occupied within the noise floor of the equipment.

Fig. 11 shows the data for a more built up urban area in the valley, where signal levels are affected by urban scattering in addition to the effects of terrain. In this case the local repeater station which is about 5 km away is roughly aligned with the street but the nearest main transmitter is perpendicular to both the buildings and terrain. The local repeater can be seen in the vertical polarisation with losses of around 15 dB as is expected from the antenna used. This situation illustrates the failings of the model when buildings are involved, because the model has no data on the size, shape or orientation of buildings, any antenna below rooftop height suffers more loss than the model

predicts.

In Fig. 12 even the local repeater predictions do not match the measurements. Prior Park road runs perpendicular to the direction of signal so the buildings either side block out even more of the signal than would be expected from the model alone. This is a worst case situation for the prediction model. Most properties in the area did seem to have TV aerials pointed at the local repeater however so it seems that at rooftop height there may be enough signal.

#### IV. CONCLUSION

In general this study has backed up the model as being representative in exposed areas. Additional design consideration and characterisation of the test antenna are required to qualify the accuracy further.

In urban areas it was found that the model was significantly in error as had been predicted. This is primarily due to diffraction losses caused by buildings. It illustrates several points, firstly that the model can not be used reliably where

any kind of obstruction (trees or buildings) is present, secondly that the protection limit imposed to avoid interference with roof-top antennas which don't suffer the same losses is clearly important. Finally it is worth noting that the predictions of more areas with signal level below the proposed protection limit can be found between buildings as this is where the limit is ideally suited to be applied.

It should also be apparent from the graphs presented that the proposed detection threshold of -120 dBm [2] is well below the noise floor. The noise figure of the WBX board used as the wide band front end for the USRP is approximately 30 dB across the band [6] resulting in a noise floor of -104 dBm in 10 kHz. Once the raw spectrum is summed into 8 MHz channels the resulting noise floor is only -75 dBm. In future work it is hoped the noise floor will be pushed lower by utilising the LNA gain features of the board, however this points out the potential difficulty of reaching a sensitive enough receiver to be able to apply the protection limits that have been suggested.

The results which have been presented in this paper back up previous suggestions that a short range cognitive standard would be most efficient. Terrain and the built environment in the UK and other European countries mean that for most people to benefit a standard more like 802.11 would be preferable to 802.22.

#### ACKNOWLEDGMENT

The authors would like to thank picoChip Designs Ltd. for sponsoring this PhD programme of study at the University of Bath.

#### REFERENCES

- [1] N. Dumont, R. J. Watson, and S. R. Pennock, "Use of the parabolic equation propagation model to predict TV white space availability," in *Proc. Loughborough Antennas and Propagation Conf. (LAPC)*, 2010, pp. 353–356.
- [2] Ofcom, "Digital Dividend: Cognitive Access," <http://stakeholders.ofcom.org.uk/binaries/consultations/cognitive/statement/statement.pdf>, July 2009. [Online]. Available: <http://stakeholders.ofcom.org.uk/binaries/consultations/cognitive/statement/statement.pdf>
- [3] C. Stevenson, G. Chouinard, Z. Lei, W. Hu, S. Shellhammer, and W. Caldwell, "IEEE 802.22: The first cognitive radio wireless regional area network standard," *IEEE Communications Magazine*, vol. 47, no. 1, pp. 130–138, 2009.
- [4] M. Levy, *Parabolic Equation Methods For Electromagnetic Wave Propagation*. The Institute of Electrical Engineers, 2000.
- [5] M. Ettus, "USRP N200 Series, ethernet software radio systems," [online] [http://www.ettus.com/downloads/ettus\\_ds\\_usrp\\_n200series\\_v3.pdf](http://www.ettus.com/downloads/ettus_ds_usrp_n200series_v3.pdf), Nov 2010.
- [6] —, "WBX receiver performance plots," [online] [http://ettus-apps.sourcerepo.com/redmine/ettus/attachments/46/imd\\_and\\_nf\\_vs\\_gain.pdf](http://ettus-apps.sourcerepo.com/redmine/ettus/attachments/46/imd_and_nf_vs_gain.pdf), Jan 2010.